

A Collection of Curricula for the STARLAB® Lewis & Clark Cylinder

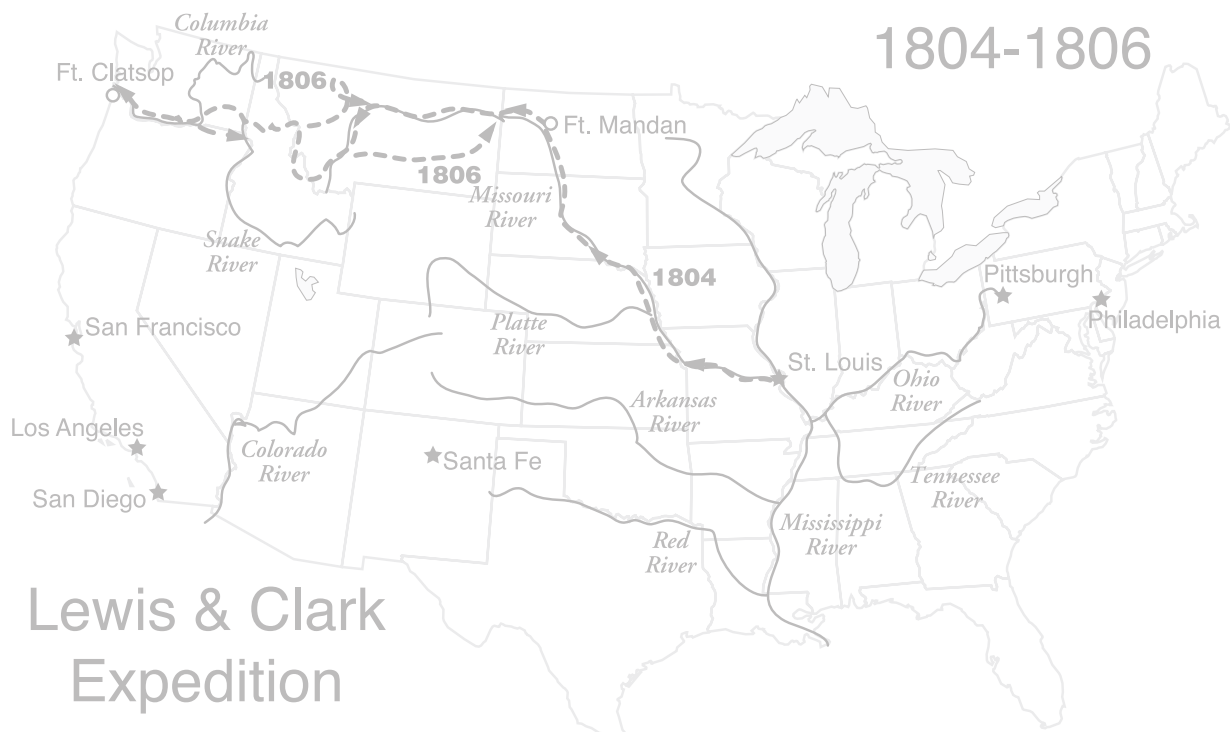

Lewis & Clark Expedition

Including:

The Celestial Navigation of Lewis & Clark: How They Knew Where They Were in the Middle of Nowhere by Eileen M. Starr, Ph.D.



Curriculum Guide Contents

<i>The Celestial Navigation of Lewis & Clark</i>	3	22. Moon Phases as Seen from the Earth	48
Introduction	3	23. How Much Does the Moon Move Each Night?...50	
Synopsis of Curriculum Activities.....	4	24. Finding Longitude Using Equal Altitudes of the Sun.....	52
Dead Reckoning.....	4	25. Finding Longitude Using a Lunar Eclipse.....	55
Latitude and Longitude	4	26. Finding Longitude Using the Moon and a Star...56	
Finding Latitude.....	5	Recommended Resources.....	58
Finding Longitude.....	6	Constellation and Star Information	61
Cylinder Reference Charts	8	The Nine Navigation Stars of Lewis & Clark	61
1. Finding the North Star, the North Celestial Pole and Directions.....	10	The Constellations of the Zodiac.....	61
2. Our Changing North Star.....	11	Aries (The Ram).....	61
3. Finding the Cardinal Directions in the Night Sky...14		Pisces (The Fishes)	61
4. Dead Reckoning.....	15	Aquarius (The Water Carrier).....	62
5. Creating Parallels of Latitude and Meridians of Longitude.....	18	Capricornus (The Goat).....	62
6. Significant Parallels on the Earth.....	20	Sagittarius (The Archer).....	62
7. Star Motion Caused by a Rotating Earth.....	22	Scorpius (The Scorpion).....	63
8. Locating the North Celestial Pole	23	Libra (The Scales)	63
9. Circumpolar Constellations	24	Virgo (The Virgin).....	63
10. How the Number of Daylight Hours Varies at Different Latitudes	25	Leo (The Lion).....	64
11. Rotation and Time.....	27	Cancer (The Crab).....	64
12. Latitude and the Sun's Altitude.....	28	Gemini (The Twins)	64
13. Determining the Altitudes of Celestial Objects Using Your Hands.....	32	Taurus (The Bull)	65
14. Finding the Sun's Altitude.....	34	The Precession Constellations	65
15. Finding Noon Using Shadow Lengths.....	35	Cepheus.....	65
16. Identifying the Ecliptic and the Zodiacal Constellations.....	37	Cygnus (The Swan).....	66
17. Day And Night.....	39	Draco (The Dragon).....	66
18. Time and Longitude.....	40	Lyra (The Lyre).....	66
19. The Nine Navigation Stars of Lewis and Clark...42		Ursa Minor (The Little Bear).....	67
20. The Relationship Between the Celestial Equator and the Ecliptic.....	44	Other Important Constellations for Lewis & Clark	67
21. Phases Of The Moon.....	45	Aquila (The Eagle).....	67
		Cassiopeia	67
		Pegasus (The Winged Horse).....	68
		Piscis Austrinus (The Southern Fish)	68
		Ursa Major (The Great Bear)	68

The Celestial Navigation of Lewis & Clark

How Lewis and Clark Knew Where They Were When They Were in the Middle of Nowhere

Introduction

The size of the United States doubled in area in 1803 with the purchase of the Louisiana Territory from France. This huge tract of mostly unexplored land stretched from the Gulf of Mexico to present day Canada and between the Mississippi River and the Rocky Mountains. President Thomas Jefferson, who had long been interested in exploring the west, could now justify such an expedition to congress because the United States required knowledge of the resources and inhabitants of the new territory as well as information about whether there was a direct water route to the Pacific.

Jefferson appointed his private secretary, Meriwether Lewis, to lead an expedition up the Missouri River and to the Pacific coast. In turn, Lewis asked William Clark to be the co-leader. On May 14, 1804, Lewis and Clark and the Corps of Discovery left St. Louis and sailed up the Missouri River. Although the region near the mouth of the Missouri was well mapped, most of the interior portion of the continent was unexplored by Europeans. During the 2 years, 4 months and 10 days of their expedition, the Corps of Discovery navigated 7,000 river miles and greatly increased the geographical and scientific knowledge about the North American continent. But, during their explorations, how did they know where they were?

Contributed
by Eileen M.
Starr, Ph.D.

Artwork created
by Andrea Colby
(many from sketches
by Eileen Starr)
except Pirate's
Map and photos.
Cylinder drawings
created by Jim
Roderick.

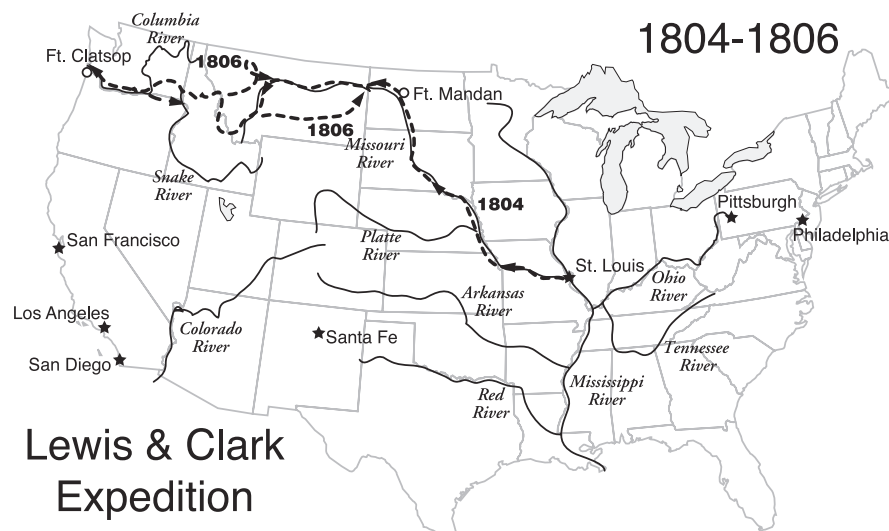

Lewis & Clark
Expedition

Synopsis of Curriculum Activities

Dead Reckoning

One way to find location is to use dead reckoning. If you know the location of your starting point, the direction in which you are traveling, the speed at which you are moving and the length of time you have travelled in that direction, you know your location relative to your starting point. North is found by finding Polaris, the North Star, located at the end of the tail of the Little Bear, or at the end of the handle of the Little Dipper. When you face Polaris, west is to your left, east is to the right, and south is directly behind you. See this concept demonstrated in the following STARLAB activities:

1. Finding the North Star, the North Celestial Pole and Directions
2. Our Changing North Star
3. Finding the Cardinal Directions in the Night Sky

For Lewis and Clark, the starting point for dead reckoning was the mouth of the Wood River near St. Louis. Using a compass, the Captains recorded the direction that they traveled throughout each day. They also estimated the distance to various landmarks, such as a fallen tree or a curve in the river, and tallied these distances at the end of the day. Their journals record each landmark and the distance to the landmark from St. Louis. But, describing a location just based on the distance from a known place isn't nearly as helpful as being able to identify a specific location — a point — on the Earth. See the student activity:

4. Dead Reckoning

Latitude and Longitude

Jefferson wanted something more exact than how far and in which direction. Jefferson's orders to Captain Lewis were: "Beginning at the mouth of the Missouri, you will take observations of latitude and longitude, at all remarkable points on the river & especially at the mouths of rivers, at rapids, at islands & other places & objects distinguished by such natural marks & characters of a durable kind, as that they may with certainty be recognized hereafter." See the student activity:

5. Creating Parallels of Latitude and Meridians of Longitude

Latitude and longitude specify a point on the Earth's surface. Imagine that a knitting needle exactly punctures an orange in half. On Earth the two points of intersection are the North and South Poles. The equator is exactly half way between the poles. Lines drawn parallel to the equator are called parallels of latitude. Lines drawn between the two poles are called meridians of longitude. Longitude is the distance east or west of an arbitrary line that runs between the North and South Poles of the Earth. The arbitrary line is called the Prime Meridian which passes through Greenwich, England. Places east of the Prime Meridian are described as having an east longitude, those places in the half of the world west of the Prime Meridian are designated as having a west longitude. The "western hemisphere" is so named because it is located west of Greenwich. If you know your latitude (the distance north or south of the equator) and you know your longitude (the distance east or west of the Prime Meridian), then you have established your position on our globe. See this concept demonstrated in the following STARLAB activity:

6. Significant Parallels on the Earth

Finding Latitude

Latitude is easier to find than longitude. In the Northern Hemisphere, the axis of the Earth if extended into space, points to an imaginary spot in the sky known as the North Celestial Pole. As you watch the stars at night, they seem to move — rising from the east and setting towards the west. Look to the north. The stars appear to be moving around the North Celestial Pole. Of course, the stars aren't moving at all. It is the Earth that is moving — turning or rotating once around its axis each day. In the sky there is nothing that shows you the North Celestial Pole. It is the point around which all of the other stars move. Look carefully. The star Polaris is located very near the North Celestial Pole. On Earth, the height or altitude of the North Celestial Pole is the same as latitude. You can find the North Celestial Pole by measuring the position of Polaris and measuring it again 12 hours later. The North Celestial Pole is located between the two positions. To use Polaris in this way for finding your exact latitude, you must have more than 12 hours of darkness. See this concept demonstrated in the following STARLAB activities:

7. Star Motion Caused by a Rotating Earth
8. Locating the North Celestial Pole
9. Circumpolar Constellations
10. How the Number of Daylight Hours Varies at Different Latitudes

Another method of finding latitude is by measuring the maximum height (altitude) of the sun at noon. Just as the Big and Little Dippers change their positions as the observer moves north or south along the surface of the Earth, the elevation of the sun also changes both daily and over the course of the year. The Earth turns on its axis. Imagine taking an orange and pushing a knitting needle through it. Now turn the orange around the needle. The orange is like the Earth and the knitting needle is like the Earth's axis. This axis is not upright when compared to the plane of the solar system but is tipped by about 23.5 degrees from vertical. During each 24-hour day, our Earth turns once around its axis. During each hour the Earth turns 15 degrees. See the following activities:

11. Rotation and Time
12. Latitude and the Sun's Altitude (in STARLAB)

The tilt of the Earth causes the sun to appear to change its path through the sky during different seasons. At noon, the sun appears highest during the summer and lowest during the winter outside the equatorial region. But elevation of the sun at noon above the horizon depends on where you are. If you measure the altitude of the sun at noon and if you know the latitude of where the sun is when it is directly overhead as listed in the *Astronomical Almanac* or *Nautical Almanac*, you can determine your latitude. See the following student activity:

13. Determining the Altitudes of Celestial Objects Using Your Hands

On the first day of spring or autumn, the sun is directly overhead at noon at the equator. At the North Pole on the same date, the sun is on the horizon — a difference of 90 degrees. If you measure the elevation of the sun and subtract that value from 90 degrees, you have determined your latitude. The calculations aren't quite so easy at other times of the year when the sun's direct days fall somewhere between the Tropic of Capricorn at 23.5 degrees south latitude, and the Tropic of Cancer, 23.5 degrees north of the equator. If you know the date, a table will give you the actual latitude of the sun, and you can determine your latitude from that. Refer to the following student activity:

14. Finding the Sun's Altitude

Lewis and Clark determined their latitude by measuring the altitude of the sun at noon

when it appeared due south. Because the sun is at its highest in the sky at noon, the shadow cast by objects will be shortest in length at noon. Refer to the following student activity:

15. Finding Noon Using Shadow Lengths

Finding Longitude

The sun also appears to change its position each day, relative to the stars. This is due to the movement (revolution) of the Earth around the sun. Constellations that lie along the sun's path are called the zodiacal constellations. The moon and planets are also found within these constellations. See the following STARLAB activity:

16. Identifying the Ecliptic and the Zodiacal Constellations

When an event happens in space, such as the moon looking like it is very close to a star, this particular separation is seen at the same instant from all places on Earth where it is visible. Using a table which predicted the moon's motions among the stars, the Captains were able to look up the time that the separation occurred at the Prime Meridian. The difference between local and Greenwich time determined their longitude. Why does this work? Finding longitude on Earth is dependent on the Earth's rotation. When the sun is at its highest point on the north-south meridian, it is local noon. When noon occurs depends on your location. See the following student activity:

17. Day and Night

Think of the sun as a light bulb hovering above the equator of our spinning globe — our Earth. The spot on the globe just moving into sunlight is experiencing dawn, the point directly under the sun is noon, and the spot just leaving sunlight is experiencing sunset. Because it takes 24 hours for the Earth to rotate once, each hour time difference between noon at the Prime Meridian and your noon (when the sun is at its highest point in the sky for the day), is equal to 15 degrees. See the student activity:

18. Time and Longitude

Longitude can also be found by measuring the angle between the moon, planets and stars. To find Greenwich time and altitudes to find local time, Lewis and Clark used an astronomical table that gave the positions of nine bright stars that lay within or near the zodiacal constellations. See the following STARLAB activities:

19. The Nine Navigation Stars of Lewis and Clark

20. The Relationship Between the Celestial Equator and the Ecliptic

The paths of the sun and moon also lie within these stars. Because of the Earth's rotation on its axis, the stars as well as the members of our solar system, seem to rise and set together. However, if you observe the sun, moon and planets for a month or more, the objects seem to change their location among the stars. As viewed from Earth, it seems to take the moon nearly 30 days, moving from west to east, to orbit 360 degrees around the Earth. Thus the moon moves about 12 degrees eastward each night. The difference in time from when the star, sun, or planet is supposed to be near the moon as seen from the Prime Meridian and the time it is seen by you from your location, will equal the difference in longitude. Captain Lewis, while at Fort Mandan, saw an eclipse of the moon on January 14, 1805. This eclipse was caused by the full moon moving into the Earth's shadow. The time of this eclipse in Greenwich time, was listed in the Astronomical Almanac. Captain Lewis knew what time he saw the eclipse. The difference in time established the longitude of Fort Mandan. See the following activities:

21. Phases of the Moon

22. Moon Phases as Seen from Earth (in STARLAB)

23. How Much Does the Moon Move Each Night? (in STARLAB)

Longitude can also be found by using equal altitudes of the sun. Two sets of observations are needed, one in the morning and another in the afternoon when the sun is at exactly the same height above the horizon as it was in the morning. The times of both readings are averaged to determine the time of local noon and then compared to Greenwich time kept by a chronometer. The sun changes altitude quickly in the morning and afternoon but very slowly near noon. Using equal altitudes of the sun was a more accurate method of finding the time of local noon than trying to find the time when the sun reached its highest point in the sky, or a shadow was at its shortest length. A sextant was used to measure the altitude of the sun. They wouldn't determine an accurate zero degree position for their measurements because of the lack of a flat horizon, so they used an artificial horizon. The result is that their altitude measurements are double the actual angle.

24. Finding Longitude Using Equal Altitudes of the Sun (in STARLAB)

How did the Captains know the time at the Prime Meridian? They used a clock that was set for Greenwich time. The instrument was called a chronometer, a watch that rested on its back in a small case. Unfortunately the Captains had some problems with their chronometer — it stopped several times even though it had been wound at noon each day. And, several times the Captains forgot to wind it because there were more pressing issues at hand such as meeting with the local inhabitants of an area or traveling over the Rocky Mountains. The Captains could not reset the chronometer with any accuracy.

They used two ways of finding longitude which did not require an accurate timepiece. One way was to observe a lunar eclipse. The time of the eclipse at Greenwich, England was given in the *Astronomical Almanac*. As soon as the eclipse began, the time difference between the unknown location and Greenwich was known. The second method was to measure the distance of a star (or planet) from the moon. The position of the stars and the location of the moon were given for eight times a day in the *Astronomical Almanac*.

25. Finding Longitude Using a Lunar Eclipse

26. Finding Longitude Using the Moon and a Star (in STARLAB)

While at Fort Clatsop, Clark used Lewis' astronomical calculations of latitude and longitude, along with his own measurements of dead reckoning to redo his maps of their trip up the Missouri and across the mountains. Considering the instruments and tables that they had to work with, the latitude and longitude measurements were remarkably accurate and provided approximate locations of many landmarks found in the lands secured by the Louisiana Purchase and the lands located farther west. The accuracy of their work, as recorded in their journals, has made it possible to recognize most of the places they explored.

Cylinder Reference Charts

Top of the Cylinder

Includes Precession Circle, Northern Celestial Pole Constellations. The Precession Circle is divided into 1000 year increments beginning with the year 0. Moving clockwise (BCE, which stands for Before Common Era) from the 2 represents years into the past. Moving counterclockwise (CE, which stands for Common Era) from the 2 represents the present and into the future.

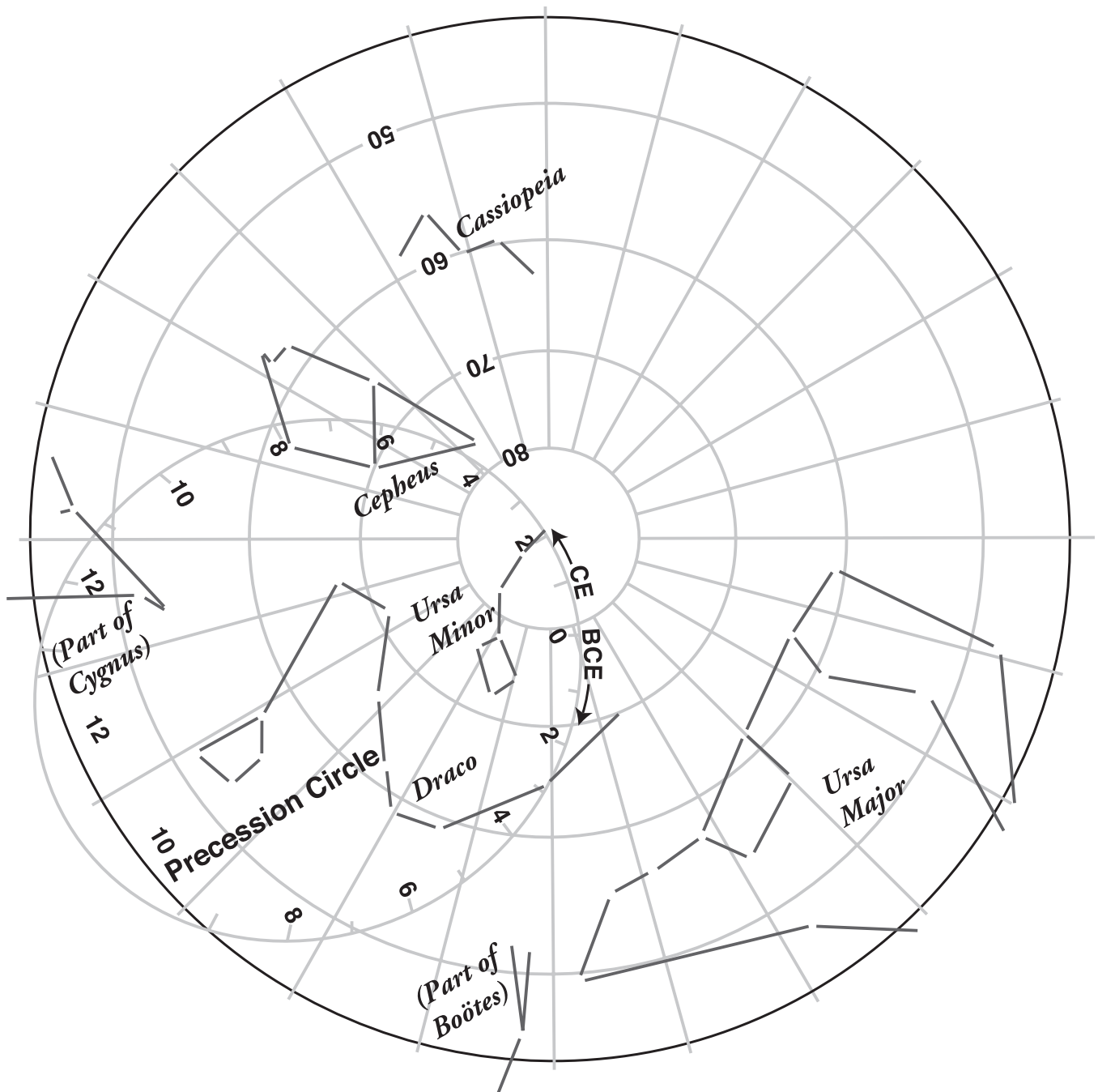

Sides of the Cylinder

Includes the zodiacal constellations, the Celestial Equator, the ecliptic and the nine navigation stars of Lewis & Clark.

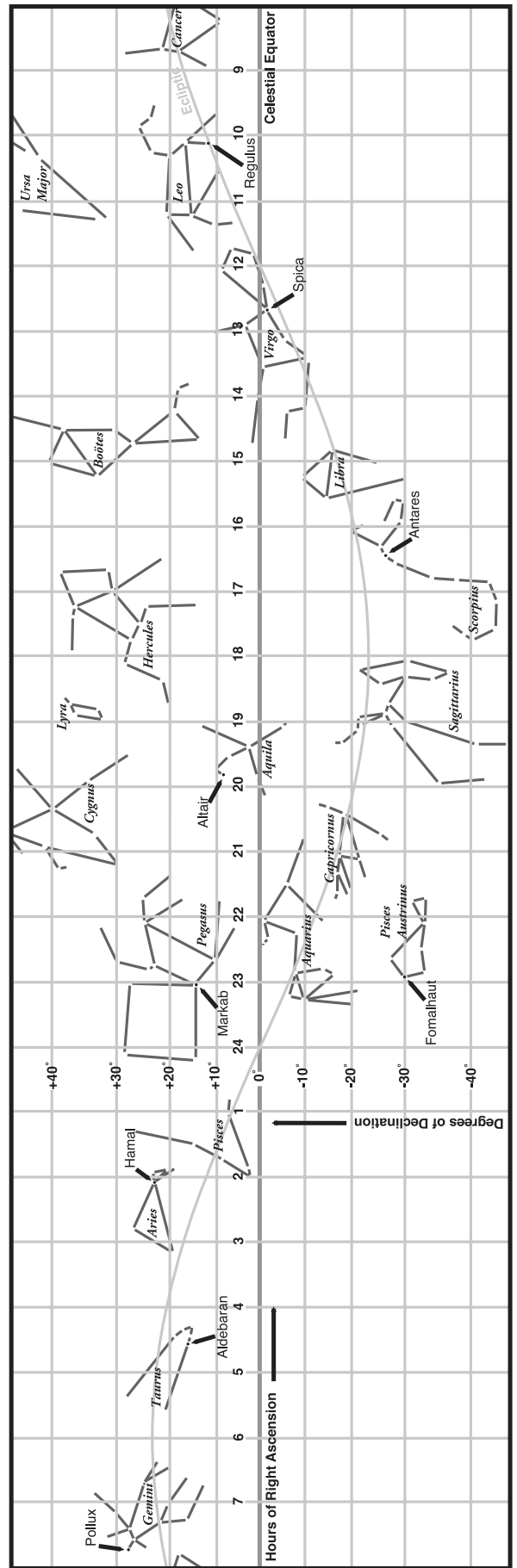

MATERIALS

- STARLAB Portable Planetarium
- Lewis & Clark Cylinder

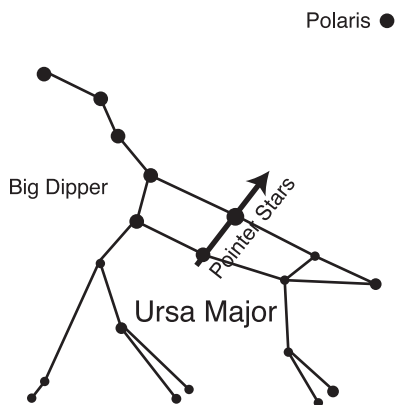

1. Finding the North Star, the North Celestial Pole and Directions

Lewis and Clark used the North Star to determine the difference between what their compass read and true north (magnetic declination). Clark used the compass readings to determine the direction that the Corps of Discovery traveled each day. This information was used, along with the estimates of how far they traveled, to determine their position, using "Dead Reckoning".

Objective

To find the North Star (Polaris) using the Big Dipper.

Integrated Subjects

Science

Process Skills

Observing • Discovering

Procedure

- Look toward the North. Look for seven stars that are nearly all the same brightness that form a Big Dipper. The Big Dipper is located within the constellation of Ursa Major, the Great Bear.
- Find the two stars located in the side of the bowl, which are not connected to the handle. These two stars are called the "Pointer" stars.
- Imagine that the Big Dipper looks like a great saucepan in the sky. Find the Pointer stars and move along them, from the bottom of the dipper (or saucepan) toward the top.
- Continue the line about five times the distance between the two Pointer stars. This line should lead to Polaris, the star at the end of the handle of the Little Dipper (or at the end of the tail of Ursa Minor, the Little Bear). In the STARLAB the stars are much closer together than in the real sky. The pointer stars may seem to not point directly to Polaris, unless the curve of the dome is taken into consideration.

2. Our Changing North Star

Lewis and Clark measured the altitude of the star, Polaris, and also noted the difference between the readings of their compass which pointed to the magnetic north pole of the Earth and the position of north as determined by Polaris. The Earth undergoes three motions:

1. Rotation — caused by the Earth turning on its axis
2. Revolution — caused by the Earth moving around the sun in a year
3. Precession — caused by the Earth wobbling on its axis. The Earth takes about 26,000 years to precess once. The effect of precession is that the position of the North Celestial Pole (NCP) changes slightly every year, but the change is so slight that one doesn't notice a difference during a lifetime. However, over thousands of years, the star, known as the North Star, changes.

Sometimes a bright star is located near the NCP. That star is then called the North Star. Currently our North Star is Polaris in the handle of the Little Dipper (in the tail of Ursa Minor, the Little Bear).

Objective

To visualize how much the North Celestial Pole (NCP) changes throughout time.

Integrated Subjects

Science • Mathematics • History • Geography

Process Skills

Observing • Interpreting

Procedure

- Find Polaris, our current North Star, in the STARLAB. Note that it is near a dashed line. This line is the **Precession Circle**. It shows where the North Celestial Pole of the past and the future is located.
- Several other bright stars have been the North Star in the past and will again be the North Star in the future. What would have been the North Star at the following times, or when the following events were taking place on Earth?

MATERIALS

- STARLAB Portable Planetarium
- Lewis & Clark Cylinder

Event	Date	Number of Years Ago or in the Future	North Star
Last Ice Age is ending	12,000 BCE	14,000 years ago	Vega, in Lyra the Harp
Egyptian pyramids are built	3,000 BCE	5,000 years ago	Thuban, in Draco the Dragon
Columbus reaches America	1492	Current date minus 1492	Polaris, in Ursa Minor
Astronauts first explore the moon	1969	Current date minus 1969	Polaris, in Ursa Minor
You are born	Your birth date	Current date minus your birth date	Polaris, in Ursa Minor
	6,000 CE	4,000 years in the future	Star in the body of Cepheus the King
	8,000 CE	6,000 years in the future	Star in the foot of Cepheus the King
	11,000 CE	9,000 years in the future	Deneb, in the Tail of Cygnus the Swan

The effect of precession can be found in the names of the Parallels of Latitude that are equal to the farthest north, and the farthest south that the sun's direct rays hit the Earth.

- The parallel that is 23.5 degrees north of the equator is known as the Tropic of Cancer. This Tropic was named for the constellation that the sun seemed to be sitting in when the sun's direct rays were at their highest altitude in the sky on the first day of summer several thousand years ago. Because of precession, now on the first day of summer, the sun seems to be sitting in the constellation of Gemini rather than in Cancer. In the STARLAB, see how precession changed the location of the summer solstice from Cancer to Gemini.
- The parallel that is 23.5 degrees south of the equator is known as the Tropic of Capricorn. This Tropic was named for the constellation that the sun seemed to be sitting in several thousand years ago when the sun's direct rays were at the lowest altitude in the sky on the first day of winter. Because of Precession, on the first day of winter the sun seems to be sitting in the constellation of Sagittarius rather than in Capricornus. In the STARLAB, see how precession changed the location of the summer solstice from Capricornus to Sagittarius.

Procedure

- Another effect of precession can be seen when you read your horoscope in the newspaper. The sun no longer sits directly among the stars of your zodiacal constellation — it is now about one constellation removed. Find your zodiacal constellation in the STARLAB.
- Using the newspaper, find your sign of the zodiac. On the chart below, enter the date you were born and your sign. On your birth date, find the constellation in which the sun appears to be located. Repeat this procedure with information for several of your friends.

Birth Date of You or a Friend	Zodiacal Sign as Given in Newspaper	Actual Constellation of Sun's Location

The Changing Location of the North Celestial Pole and North Star

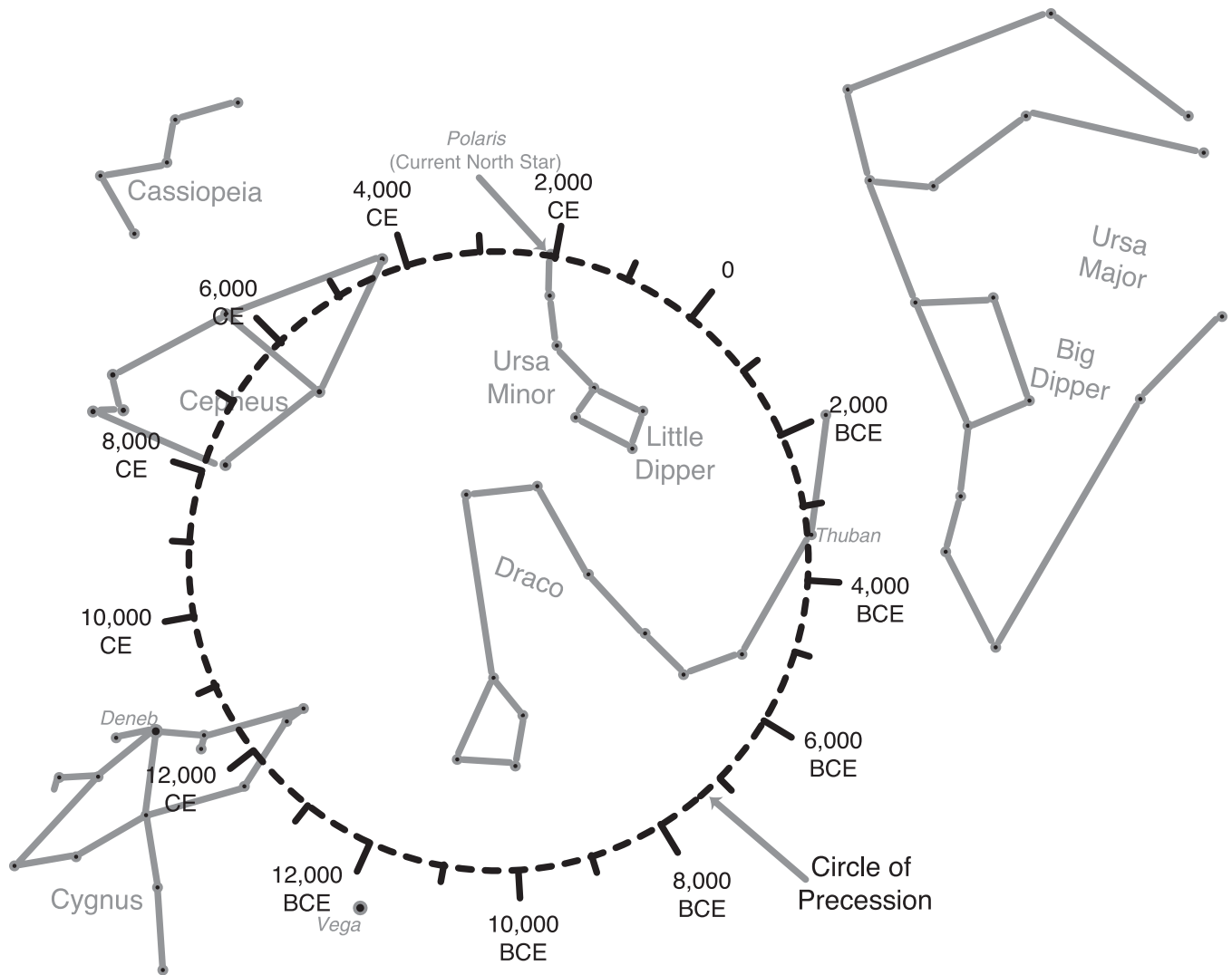

MATERIALS

- STARLAB Portable Planetarium
- Lewis & Clark Cylinder

3. Finding the Cardinal Directions in the Night Sky

Lewis and Clark used directions to determine when the sun was due south (Noon), and to determine the relationship of their compass readings (which were reading magnetic north), to true north.

Objective

Using the North Star to find the directions of south, east and west.

Integrated Subjects

Science • Geography

Process Skills

Observing • Discovering

Procedure

- Find the North Star (see activity 1. Finding the North Star). When you face the North Star (Polaris), you are facing north. South is behind you.
- Hold your right arm straight out from your body toward your side. Your arm is pointing toward the east.
- Your left arm, when it is held straight out, and 90 degrees from north, points toward the direction of west.
- Turn around and face south. Point to the direction south (in front of you). Point to the direction north (behind you). Point to the east (your left arm straight out). Point to the west (your right arm straight out).

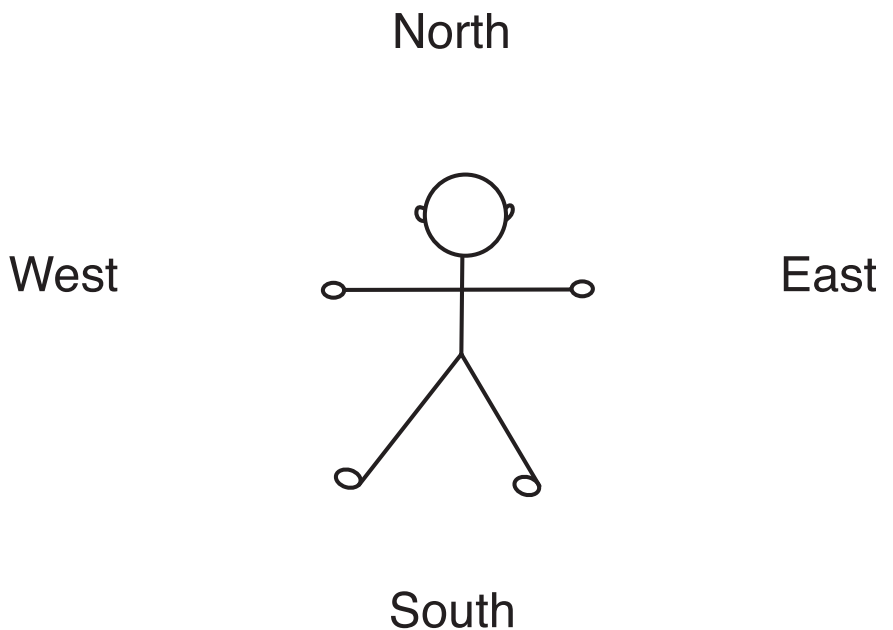

4. Dead Reckoning

Captains of ships at sea used the concept of “Dead Reckoning” to determine where they were in relation to their home port. Lewis and Clark also used dead reckoning to determine where they were in relation to their starting point — Fort Wood (near St. Louis, Missouri).

Maps, which gave directions to find buried treasure, also used the principles of dead reckoning. Those principles are:

1. Which direction do I go?
2. How long do I continue going in this direction?

William Clark was the dead reckoning expert on the Voyage of Discovery. Using a compass, Clark determined the many changing directions the Corps of Discovery made while traveling up the Missouri River and across the mountains. He also recorded how long they traveled in each direction. When the river turned, a new compass direction was noted, as well as an estimate of the number of miles traversed.

Although the compass directions recorded by Clark did not correct for magnetic declination, magnetic declination was recorded for many localities by calculating the difference between Polaris and the compass. Clark estimated the group had traveled 4,134 river miles between the mouth of the Missouri and the Pacific Ocean. He was accurate to within 40 miles, or to within one percent of the actual distance.

Objective

To determine the location of buried treasure using the methodology of dead reckoning.

Integrated Subjects

Science • Art

Processing Skills

Describing • Observing • Drawing • Communicating • Interpreting • Inferring
• Working cooperatively

Procedure

Whole Group Activity

- A magnetic compass shows the direction of magnetic north. For this activity, assume that magnetic north and true north are the same.
- Show the students how to find directions using a magnetic compass. Have younger students use only the four cardinal points of north, south, east, and west. Intermediate students can use 8 divisions of direction: N, NE, E, SE, S, SW, W, and NW. Older students may be able to use the number of degrees east of north.
- Decide the measuring unit that will be used to measure distance. An easy measuring unit is a “pace”. Decide on the size of a “pace”. Is this a normal walking step, or a giant step?
- Have the class, in unison, practice a “pace” so that the “pace” is standardized.

Small Group Activity

MATERIALS

- a roll of pennies
- a magnetic compass for each small group
- paper
- pencils for class members

- Divide the students evenly into two large groups (such as the “Reds” and the “Blues”) and then subdivide each large group into small groups composed of two or three students.
- Send all of the small groups from the same large group (the Reds, for example) outside. Each small group should have a compass and a penny.
- Have each of the small student groups find a place to hide their penny, such as at the base of a tree or on a rock.
- Beginning at a prearranged starting point, have the students use the compass to select a direction, count out a certain number of steps going in that direction, and record the direction and number of paces. (An example might be “travel due east 15 paces.”)
- Then, starting from where the first direction and distance ended, have the group select another direction, again pace out a given number of steps, and record the direction and number of paces. (An example might be “travel due north for 30 paces.”)
- Repeat the direction change and pacing again. The last change of direction and pacing should lead to the place where the penny is hidden. Again, record the direction and number of paces.
- Finally, have each small group of Reds students prepare a pirate map showing the direction and number of paces needed to move between the starting point and the penny. See page 15 for a sample pirate map.
- Give a Red map to each of the small Blue groups and have the Blues follow the directions given by the first group of Reds to find the penny. If the Blue group is successful in finding the penny, the Red group receives two points because they created an accurate map. The Blue group receives one point for finding the penny.
- Have the groups exchange roles. The initial “hidiers” (the Reds) become the ones to follow the directions devised by the Blues to find the penny.
- Tally the number of points that each large group earned. The large group having the highest number is the winner.

**River Miles from the Wood River
Dead Reckoning Calculations
by William Clark, Winter, 1804-5**

To:	To:
St. Charles21 miles	2nd Old Village of Kansas 433 miles
Gasconade 104 miles	Nadawa River..... 481 miles
Osage River 138 miles	Big Ne-ma-har River 511 miles
Mine River201 miles	Mouth of the Platte River 632 miles
Old Village of Misuries.....246 miles	Council Bluffs 682 miles
Grand River254 miles	Little Sioux River766 miles
Kansas River336 miles	The Mouth of the Big Sioux River 880 miles

Pirate's Map

N

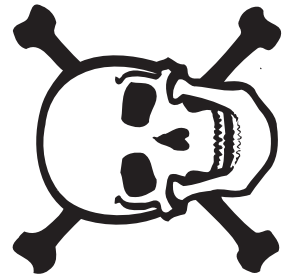
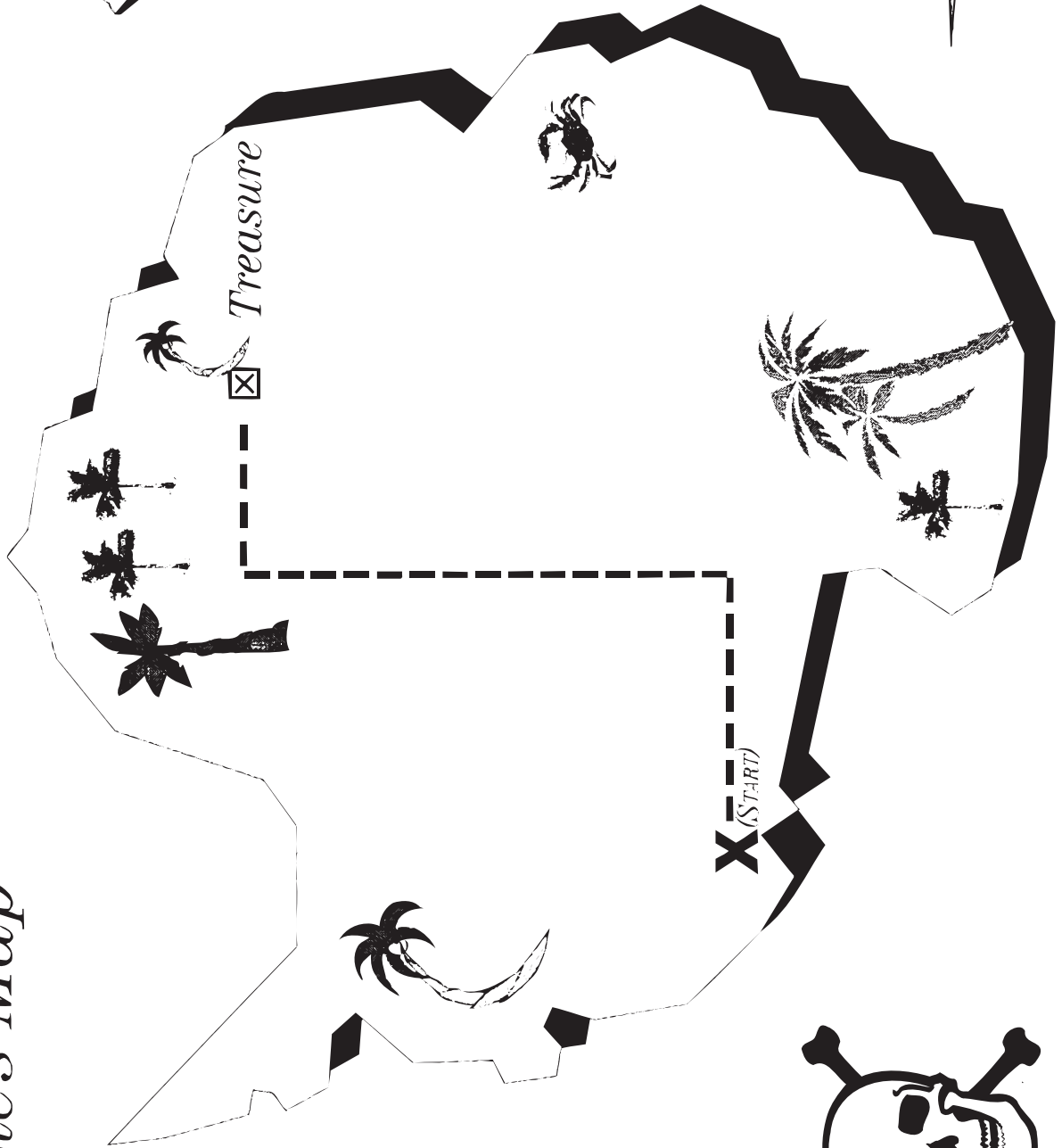
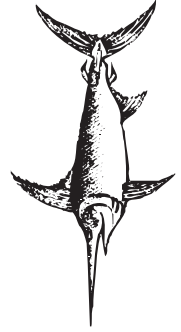
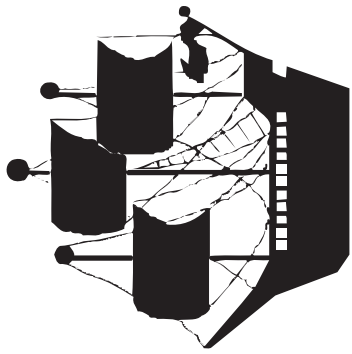

MATERIALS

- one orange
- a permanent felt-tipped pen
- measuring tape

5. Creating Parallels of Latitude and Meridians of Longitude

The methods used by Lewis and Clark to determine their position on the Earth required ways to measure their latitude and longitude.

An orange, like the Earth, is shaped like a sphere. To find the location of a point on the orange, or on the Earth, one can use latitude and longitude. Latitude is the distance in degrees north or south of the equator. Longitude is the measure of distance in degrees either east or west of the Prime Meridian which runs through Greenwich, England.

Objective

To demonstrate parallels of latitude and meridians of longitude.

Integrated Subjects

Science • Mathematics

Processing Skills

Observing • Measuring • Drawing • Inferring

Procedure

Orange: Step #1 — Latitude

- Measure the distance around the orange from the stem scar, around the bottom, and back to the stem scar. This circumference of the orange is equal to 360 degrees. The distance between the top of the orange and the bottom of the orange is equal to 180 degrees.
- Find the point midway between the stem scar and the bottom of the orange at several places on the orange. Using the pen, draw a line connecting the midpoints of the orange. This midpoint line is similar to the equator of the Earth. The distance between the midpoint and the stem scar is ninety degrees.
- Measure the orange between the midpoint and the stem scar. Divide this distance into one-third and two-third distances at several points along the orange.
- Connect together the one-third points, and the two-third points. The connected one-third points are the **parallels of latitude** equaling thirty degrees. The connected two-third points are the parallels of latitude equaling sixty degrees. Note that the **Lines of Parallels** are parallel to each other. Label each parallel. (See Latitude illustration.)

Orange: Step #2 — Longitude

- Measure the distance around the middle (the equator) of the orange, and divide the distance (circumference) into 6 equal divisions, marking each division. (See Longitude illustration.)
- Arbitrarily select a point on the orange. Mark it with an "X".
- Draw a line from the stem scar of the orange, through the "X" and continue the line to the equator and then to the bottom of the orange. Label this line as "0" on the equator. This has been designated as the **Prime Meridian**.
- Now draw additional meridians, from the top to the bottom of the orange and through the marks at the equator. Label the lines on either side of the Prime

Meridian as 60 degrees. The line to the right of the zero point should be labeled 60 degrees east. The line to the left of the zero point should be labeled as 60 degrees west. The next lines should be labeled 120 degrees, east and west.

- The extension of the Prime Meridian around the orange, which equals 180 degrees both east and west on the orange, is similar to the International Date Line on Earth.

Extension

Have the students place an X at the location of their town on the orange, pretending that the orange is the Earth. If the Prime Meridian ran through your town, would it make a difference as to date and time as you went across the Prime Meridian? What would happen if the International Date Line ran through your town?

Latitude

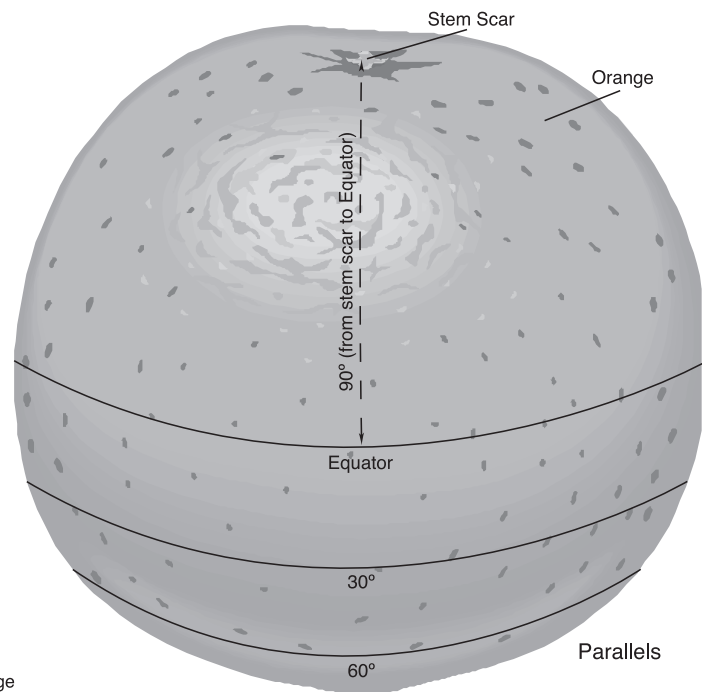

Longitude

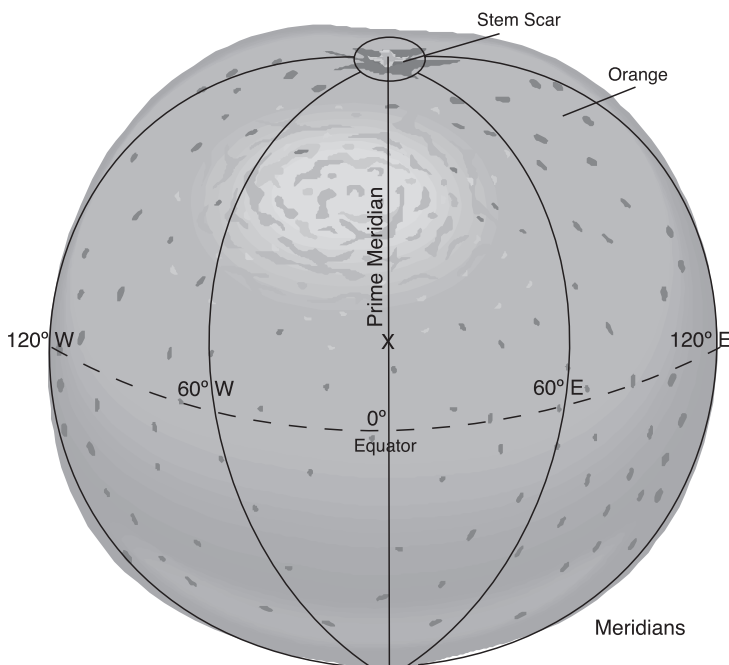

MATERIALS

- STARLAB Portable Planetarium
- Lewis & Clark Cylinder

6. Significant Parallels on the Earth

Lewis and Clark found where they were on Earth by determining their position. They used latitude and longitude to describe their location.

Objective

To locate the significant parallels of latitude on Earth.

Integrated Subjects

Science • Mathematics • Geography

Process Skills

Observing • Interpreting

Procedure

- Imagine that you could sit in the very center of the Earth, and that the Earth was transparent so that you could look into space. Certain imaginary lines found on the Earth are formed from events that occur in space. We can see those events in the STARLAB.
- Find the Earth's equator, and pretend you can see through it into space. The extension of the Earth's equator in space is called the **Celestial Equator**. Find the Celestial Equator on the STARLAB dome.
- The path of the sun is called the ecliptic. The sun passes through twelve constellations throughout the year. Find the ecliptic on the STARLAB dome and the constellations that lie along the path of the sun. The constellations are called the **Signs of the Zodiac**.
- If you were to watch the sun and plot its path over a year, you would find that sun's direct rays reached a high of 23.5 degrees above the Celestial Equator. This occurs on June 21, because the Earth is tilted 23.5 degrees in relation to the sun, and the Northern Hemisphere of the Earth is facing directly towards the sun. Several thousand years ago when the sun was at its most northerly position, it appeared to be sitting in one of the signs of the zodiac, the constellation of Cancer. The imaginary line on Earth that is 23.5 degrees north of the equator is called the **Tropic of Cancer**. Look at the ecliptic and find its most northerly position. That defines the Tropic of Cancer on the Earth.
- Because of the tilt of the Earth, part of the Northern Hemisphere experiences 24 hours of daylight in the summer. The line of 24 hours of daylight in the Northern Hemisphere is termed the **Arctic Circle**. The Arctic Circle is located at a latitude of 66.5 degrees north.
- The point directly above the north axis of the Earth has a latitude of 90 degrees. Instead of being a line of parallel, the 90 degree north parallel is a point, called the **North Pole**. The point in space is called the **North Celestial Pole**. The star Polaris is located near the North Celestial Pole. Find this star at the end of the tail of the Little Bear.
- Twice a year the sun's direct rays fall upon the equator of the Earth when the sun, traveling along the ecliptic, crosses the Celestial Equator. When the sun is moving across the equator from the Southern Hemisphere into the Northern Hemisphere, it is the first day of spring, also called the **Vernal Equinox**. What constellation is located at the Vernal Equinox?

- When direct rays fall on the equator as the sun is moving from the Northern Hemisphere into the Southern Hemisphere, it is the first day of autumn known as the Autumnal Equinox and falls on/about the 23rd of September. What constellation is located at the Autumnal Equinox?
- The sun's direct rays hit farthest south on the first day of winter, about December 22, when the Northern Hemisphere of the Earth points directly away from the sun. When this happened several thousand years ago, the sun appeared to be located in the constellation of Capricornus. The imaginary line that is 23.5 degrees south of the equator is called the **Tropic of Capricorn**.
- Because of the tilt of the Earth, part of the Southern Hemisphere experiences 24 hours of darkness during the northern summer. The line of 24 hours of darkness during the Northern Hemisphere summer is called the **Antarctic Circle**. The Antarctic Circle is located at latitude 66.5 degrees South.
- The point located on the Earth at the south axis of the Earth has a latitude of 90 degrees south. Instead of being a line of parallel, the 90 degree south parallel is a point, called the **South Pole**. In space this point is called the **South Celestial Pole**. There is no bright star located near the South Celestial Pole.

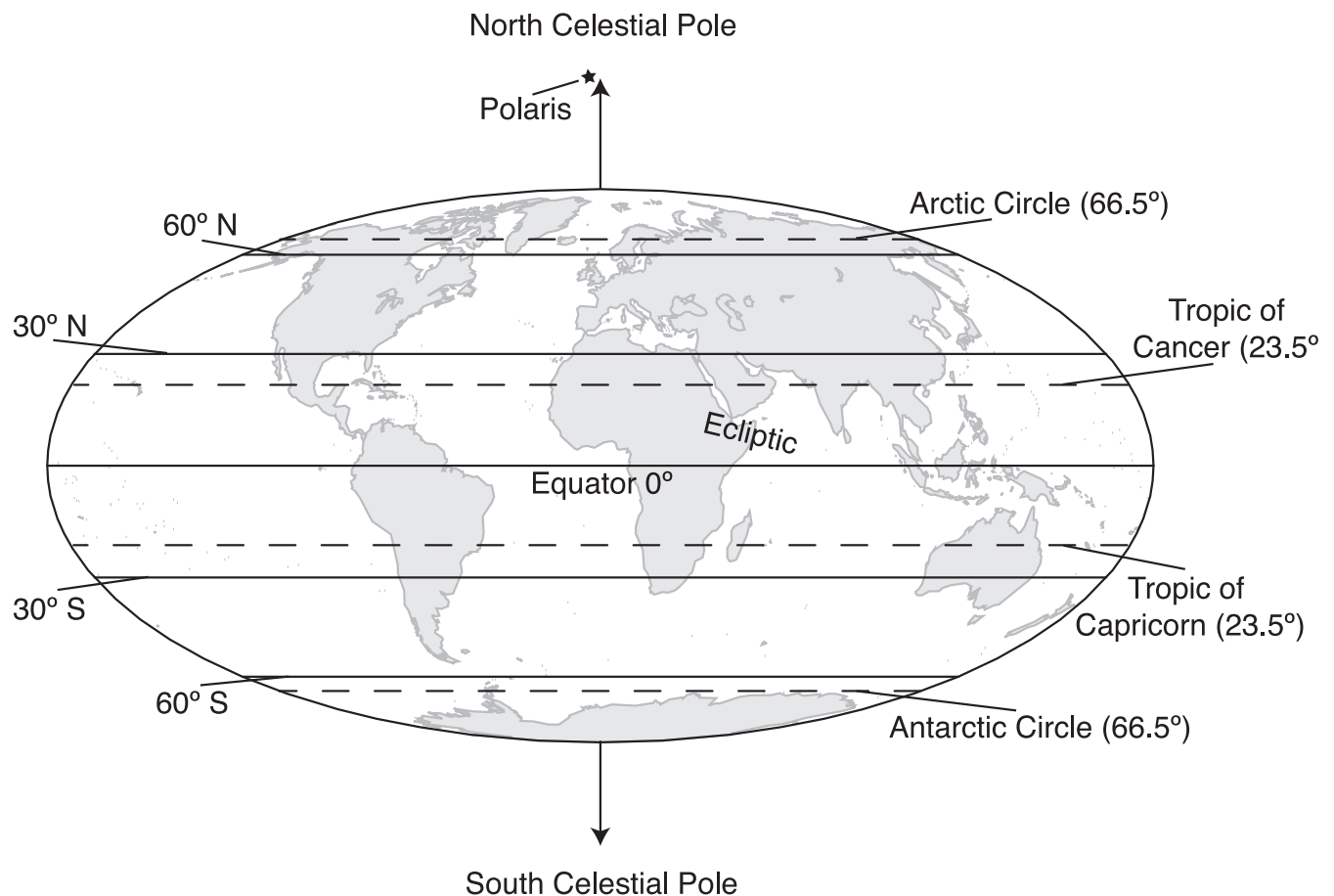

MATERIALS

- STARLAB Portable Planetarium
- Northern Starfield Cylinder

7. Star Motion Caused by a Rotating Earth

When Lewis and Clark looked at the stars at night, the constellations were not always in the same spot. Some star groups seemed to be visible all night long, others appeared to rise and set. It is the rotation of the Earth on its axis that makes it appear that the stars are changing position.

The Earth rotates on its axis once a day (24 hours). But to us on Earth, it appears that the stars are moving. When you look toward the east, the stars appear to be rising or moving from below to above the horizon. When you look south, the stars seem to be moving across the sky. When you look west, the stars seem to be setting or sinking into the horizon. As you look toward the north, the stars seem to move counterclockwise around a point called the North Celestial Pole which is near the star Polaris, our current North Star.

Objective

To observe star motions.

Integrated Subjects

Science

Process Skills

Observing • Discovering

Procedure

Star Motion

- With the Starfield Cylinder on the STARLAB Projector, turn on the daily motion.
- Have the students look south and then describe how the stars seem to be moving. Where are the stars rising? (East.) Where are the stars setting? (West.) When looking south, the stars appear to move clockwise.
- Have the students look north. Are these circling stars moving the way a clock moves (clockwise) or backwards from clock motion (counterclockwise)? When looking north, the stars look like they are moving counterclockwise around Polaris.
- Discuss which is actually moving — the stars or the Earth.

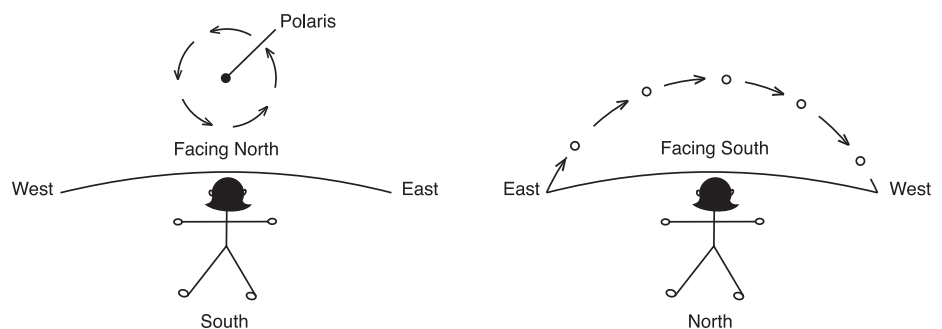

8. Locating the North Celestial Pole

One way to find latitude is to find and then measure the altitude of the North Celestial Pole above the horizon. The North Celestial Pole, located in the sky above the north axis of the Earth, shows true north. The observer's latitude is equal to the altitude of the North Celestial Pole above the horizon.

Although Polaris is called the North Star, it does not exactly mark north, nor your latitude.

Objective

To find the location of the North Celestial Pole (the point directly above the North axis of the Earth).

Integrated Subjects

Science • Art

Process Skills

Observing • Measuring • Plotting • Drawing

Procedure

- Demonstrate that the rotation of the Earth makes it appear to us that the stars are moving counterclockwise around us.
- Locate the star Polaris (see activity 1. Finding the North Star, the North Celestial Pole and Directions), place the square paper on the dome and mark the position of Polaris.
- Move through six hours of time, or one season, and again mark the position of Polaris on the square paper.
- Continue through another six hours of time, and again mark the position of Polaris. On the paper, draw a line connecting the first position of Polaris, and this third position of Polaris.
- Move through the another six hours of time, and plot the position of Polaris on the paper. Draw a line connecting the second dot, and this fourth dot. The point of intersection of the two lines shows the location of the North Celestial Pole.
- Using new paper and pencil or crayons, have the students draw and label the Big Dipper, the Little Dipper, and the star Polaris. Draw in the location of the North Celestial Pole in relation to these stars. Label the North Celestial Pole with the letters "NCP".
- Remove the square paper from the dome. Ask the students to locate the NCP at various times during the night. This can be easily done by turning their paper so that the position of the two Dippers on their papers looks like the position of the two Dippers in the planetarium sky.
- The somewhat bright star located near the point is the star Polaris. We also call this star "The North Star" because it shows us which way is north.

MATERIALS

- STARLAB Portable Planetarium
- Lewis & Clark Cylinder
- 8½" square of paper
- masking tape to connect paper to dome
- pencils or crayons
- 8½" x 11" paper

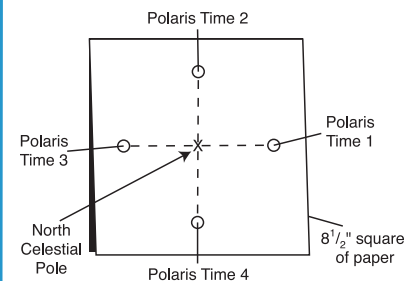

MATERIALS

- STARLAB Portable Planetarium
- Lewis & Clark Cylinder
- Starfield Cylinder

9. Circumpolar Constellations

Lewis and Clark observed the sky at night, but the sky looked slightly different as they changed latitude. In the northern sky, the circumpolar constellations (those visible every night) changed their position, depending on the latitude of the explorers. For the Lewis and Clark expedition, the latitude varied between 38 degrees and 38 minutes North at St. Louis, to 46 degrees and 11 minutes North at the mouth of the Columbia River.

Objective

To discover how the circumpolar constellations change depending on latitude.

Integrated Subjects

Science • Geography

Process Skills

Pattern Finding • Prediction

Procedure

- Set the STARLAB for the latitude of 50 degrees. Turn on daily motion. Identify the constellations that are located between Polaris and the horizon. These constellations are visible whenever it is night, although their positions change in relation to clock time, depending on the season. They are called the "circumpolar" constellations.
- Reset the STARLAB latitude for 40 degrees. Move forward in daily motion. Are all parts of the constellations visible at 50 degrees, still visible at 40 degrees? Predict how the circumpolar constellations will change when the latitude is changed to 30 degrees, or to 20 degrees.
- Predict how many constellations are circumpolar at the equator. (None.) How many constellations visible from the North Pole, are circumpolar? (All that are visible are circumpolar.)

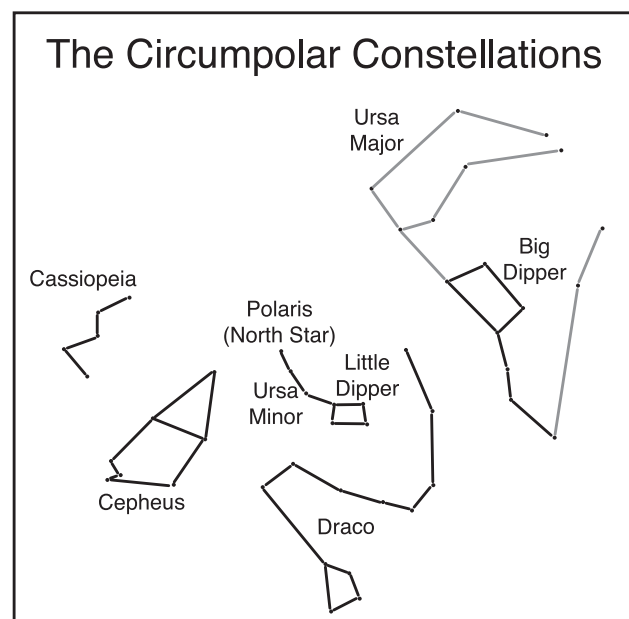

10. How the Number of Daylight Hours Varies at Different Latitudes

Throughout any one year, Lewis and Clark experienced differing amounts of daylight and nighttime hours. The amount of daylight and darkness at any point of the Earth depends both on the tilt of the Earth's axis in relation to the sun, and on latitude.

Objective

To investigate how the number of daylight hours varies at different latitudes on the Earth.

Integrated Subjects

Science • Geography

Process Skills

Observing • Discovering • Inferring

Procedure

- Find the STARLAB sun located on the first day of spring (where the ecliptic and Celestial Equator intersect). Set the STARLAB projector at zero degrees latitude. Move the springtime sun so that it is just rising in the east. Count the number of meridian lines located along the Celestial Equator (0 degrees latitude) between the sunrise and sunset points. This is the number of daylight hours at the equator.
- Move the STARLAB projector so that it set at a latitude of thirty degrees. Move the sun to the sunrise position and count the number of meridian lines located along the Celestial Equator between the sunrise and sunset points. This is the number of daylight hours at thirty degrees north latitude. How do the number of daylight hours differ from the equator? Based on the daylight hours of 0 degrees and 30 degrees, estimate the number of daylight hours at 50 degrees. Does the actual number of hours agree with your estimate when measured on the STARLAB Celestial Equator?
- Repeat the above steps using the sun located at the summer solstice counting the meridians along +23.5 declination. How does the number of daylight hours change as the latitude is changed? How does the number of daylight hours change between spring and summer?
- Estimate the number of daylight hours at each latitude at the Autumnal Equinox measuring along the Celestial Equator. Check your estimates using the STARLAB. To find the number of daylight hours at the winter solstice, count along -23.5 declination.
- Complete the following table. The number of nighttime hours is found by subtracting the number of daylight hours from the number of hours in a day (24). See chart next page.

MATERIALS

- STARLAB Portable Planetarium
- Lewis & Clark Cylinder

Sun Location	Latitude	Estimate of of Daylight Hours	Actual number of Daylight Hours	Number of Nighttime Hours
<i>Spring</i>	<i>Equator – 0 degrees</i>			
<i>Summer</i>	<i>Equator</i>			
<i>Autumn</i>	<i>Equator</i>			
<i>Winter</i>	<i>Equator</i>			
<i>Spring</i>	<i>30 degrees N</i>			
<i>Summer</i>	<i>30 degrees N</i>			
<i>Autumn</i>	<i>30 degrees N</i>			
<i>Winter</i>	<i>30 degrees N</i>			
<i>Spring</i>	<i>50 degrees N</i>			
<i>Summer</i>	<i>50 degrees N</i>			
<i>Autumn</i>	<i>50 degrees N</i>			
<i>Winter</i>	<i>50 degrees N</i>			

11. Rotation and Time

Lewis and Clark used the difference in the time of where they were, to the time in England. This helped them determine their longitude.

Objective

To investigate the relationship between the Earth's period of rotation and how this affects how time changes on Earth.

Integrated Subjects

Science • Geography

Process Skills

Observing • Interpreting

Procedure

- Place a light bulb in front of a globe so that the Prime Meridian (which runs through Greenwich, England) is directly in front of the light. The Prime Meridian is at a noon position. The Earth turns counterclockwise when viewed from the North Pole area.
- Turn the Earth globe counterclockwise when viewed from the North Pole so that North America moves toward the light. As North America moves towards the noon position, time is changing from early morning to later in the morning. When North America moves under the light, it is noon.
- Continue moving the Earth until North America is moving away from the light and into the dark portion of the globe. North America is moving from daylight into darkness. When North America moves directly behind the light, it is midnight.
- The Earth turns 360 degrees once every 24 hours. Therefore during each one hour of time, the Earth turns fifteen degrees ($360 \text{ degrees} \div 24 \text{ hours} = 15 \text{ degrees per hour}$).

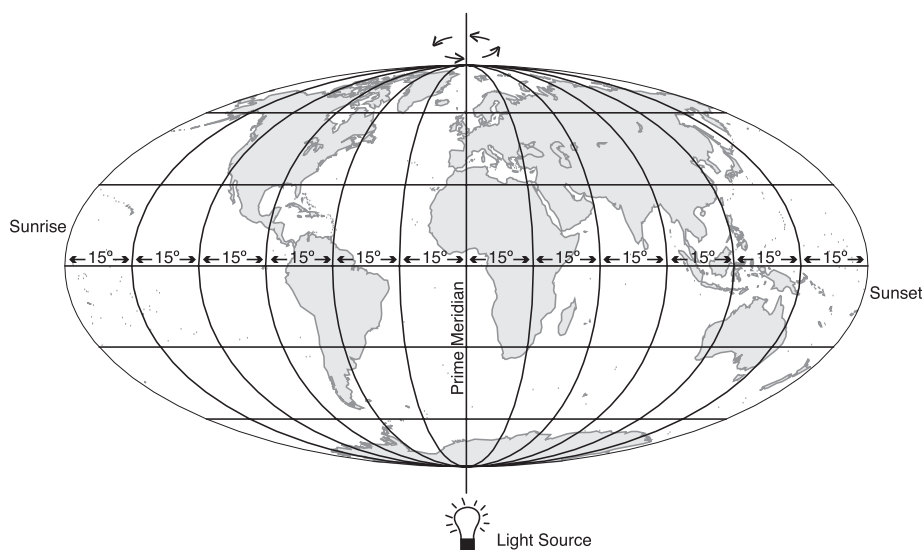

MATERIALS

- globe of the Earth
- light source

MATERIALS

- STARLAB Portable Planetarium
- Lewis & Clark Cylinder

12. Latitude and the Sun's Altitude

To determine where the Corps of Discovery were on Earth, the Captains needed to find their latitude. The altitude of the sun at noon on any day of the year is related to the latitude of the observer, but this altitude changes daily. To determine the height of the sun above the horizon at noon at a particular location on Earth, it is necessary to know the position of the sun's direct rays on the Earth. At the Vernal Equinox in March or the Autumnal Equinox in September, the sun's direct rays hit the equator, at latitude 0 degrees. At the Summer Solstice in June, the sun's direct rays hit the Earth at 23.5 degrees north of the Equator (+23.5 degrees). At the Winter Solstice in December, the sun's direct rays hit at 23.5 degrees south of the equator (-23.5 degrees).

Objective

To determine latitude by using the altitude of the sun above the horizon at noon.

Integrated Subjects

Science • Mathematics • Social Studies

Processing Skills

Observing • Measuring • Adding Positive and Negative Numbers • Calculating

Procedure

- To find latitude (location in degrees, north or south of the Earth's equator), determine where the sun's direct rays are hitting the Earth on the day of the activity by using the Apparent Declination of the Sun Throughout the Year table. Note: apparent declination is a positive or negative number. Or, use the STARLAB declination parallels to estimate the number of degrees that the sun is located above or below the Celestial Equator on that day. If the sun is located above the Celestial Equator in STARLAB, the declination is positive. If the sun is located below the Celestial Equator, the declination is negative.
- Latitude can be found by using the equation:

$$\text{Latitude} = 90 \text{ degrees} - \text{the Sun's Altitude} + \text{the Declination of the Sun.}$$

Warning

Do not do this activity outside with the real sun. Eye damage can result!

- Set the STARLAB projector for your latitude.
- Place the sun in the correct sky position along the ecliptic for the month and move the sun until it reaches its highest position in the planetarium (noon).
- Measure the altitude of STARLAB Celestial Equator objects from the STARLAB horizon. Make a sextant by attaching two LED pointers to a blackboard compass. Use a blackboard protractor to measure the angle. Make your sextant measurements from the center of the planetarium, right near the projector.
- The declination of the sun for any day of the year can be recorded by finding that date along the ecliptic in the STARLAB and measuring how far north or south the sun is from the Celestial Equator in degrees (or by referring to the accompanying table). Thus the equation can be solved for latitude.

Examples

Example 1

Let's assume that you measured the altitude of the sun on April 12. The apparent declination of the sun on that day was, according to the Table, +8 degrees and 49 minutes. If the altitude of the sun in the STARLAB was measured at 39 degrees, add 8 degrees to the 39 degrees equalling 47 degrees. Subtract the 47 degrees from 90 degrees. Your latitude is 43 degrees north (90 degrees - 47 degrees = 43 degrees).

Example 2

Suppose you measured the altitude of the sun at noon on November 1 as 28 degrees. The Apparent Declination Table tells you that the sun's apparent declination on November 1 is -14 degrees. If the altitude of the sun is measured as 28 degrees in the STARLAB, the equation is:

$$\text{Latitude} = 90 \text{ degrees} - \text{the sun's altitude} + \text{the declination of the sun}$$

$$\text{Latitude} = 90 \text{ degrees} - 28 \text{ degrees} + (-14 \text{ degrees})$$

90 degrees - 28 degrees = 62 degrees. Adding a negative number is the same as subtracting a positive number. The -14 is subtracted from 62 which gives 48. Your latitude is 48 degrees.

Declination of the Sun Throughout the Year Chart

This can also be thought of as the latitude at which the sun passes overhead at noon.

Date	Declination* Deg/min	Date	Declination Deg/min	Date	Declination Deg/min
JAN 0	-23/08	MAY 1	+14/52	SEP 1	+8/32
4	-22/47	4	+15/46	4	+7/26
8	-22/20	8	+16/54	8	+5/57
12	-21/45	12	+17/58	12	+4/27
16	-21/94	16	+18/56	16	+2/55
20	-20/16	20	+19/50	20	+1/22
24	-19/22	24	+20/38	24	-0/11
28	-18/22	28	+21/21	28	-1/45
FEB 1	-17/17	JUN 1	+21/57	OCT 1	-2/55
4	-16/25	4	+22/21	4	-4/05
8	-15/12	8	+22/47	8	-5/37
12	-13/55	12	+23/06	12	-7/08
16	-12/34	16	+23/19	16	-8/38
20	-11/10	20	+23/26	20	-10/05
24	-9/43	24	+23/25	24	-11/30
28	-8/13	28	+23/18	28	-12/53
MAR 1	-7/51	JUL 1	+23/09	NOV 1	-14/12
4	-6/42	4	+22/56	4	-15/09
8	-5/09	8	+22/33	8	-16/22
12	-3/35	12	+22/04	12	-17/30
16	-2/00	16	+21/28	16	-18/33
20	-0/26	20	+20/47	20	-19/32
24	+1/09	24	+20/01	24	-20/24
28	+2/43	28	+19/08	28	-21/11
APR 1	+4/17	AUG 1	+18/11	DEC 1	-21/41
4	+5/26	4	+17/25	4	-22/08
8	+6/57	8	+16/20	8	-22/38
12	+8/49	12	+15/11	12	-23/01
16	+9/53	16	+13/57	16	-23/17
20	+11/17	20	+12/40	20	-23/25
24	+12/38	24	+11/20	24	-23/25
28	+13/56	28	+9/57	28	-23/19

* The number of degrees either north (+) or south (-) of the Earth's equator where the direct rays of the sun fall during of the year.

Altitude of the Sun at Noon

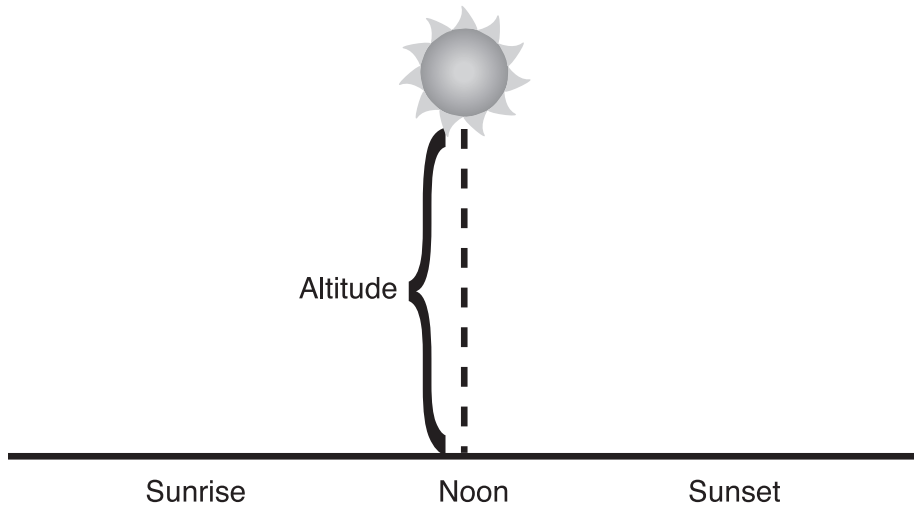

MATERIALS

- night sky or classroom

13. Determining the Altitudes of Celestial Objects Using Your Hands

Lewis and Clark found their location by using a sextant to measure the height (or altitude) of the sun, moon, planets, or stars above the horizon. Instead of a sextant, we will learn how to use our hands to estimate altitude. Because people have different sized hands and arms, we will first calibrate the size of the students' hands using the altitude of Polaris. Although young students have small hands and short arms, the ratio of arm-to-hand should be constant no matter the age.

This activity should be completed outside at night. The procedure can be practiced in the classroom.

Objective

To demonstrate how a hand can be calibrated and used to measure celestial objects.

Integrated Subjects

Science • Mathematics

Processing Skills

Observing • Measuring • Interpreting

Procedure

- Find your latitude by using an atlas, map, or web site. Your latitude is equal to the altitude of the North Celestial Pole above the northern horizon.

Calibrating Your Student's Fist, Hand, Finger and Thumb

- **Fist:** Have your students hold their arms out in front of them and make a fist with each hand. Hold the fists vertically and have the thumb tucked into the fist. Line up one fist with the horizon. Stack the two hands on top of each other until they reach Polaris. Theoretically each fist should measure 10 degrees. However, fists do vary in size. Compare the variation in each student's measurements. If a larger fist is needed to make 10 degrees, move the thumbs so that each thumb lies on top of the fist, and measure again. Very small hands may require the thumb to be bent and wedged under the index finger to make 10 degrees. If the student's hand is large, try tucking the thumb as far into the palm as possible, then measure again.
- **Hand 1:** Holding their hands at arms length, have the students measure the distance between the end of their index finger and the end of their little finger (pinkie). The average hand should measure about 15 degrees. The easiest way to measure is to fold down the fingers into the palm and then stretch the fingers. If the measurement is too large, try changing the distance of the index finger. If the measurement is too small, try stretching the index finger away from the rest of the hand.
- **Hand 2:** Have the students hold their hands at arms length. The distance between the end of their thumb and the pinkie should be about 20 degrees. The easiest way to measure is to fold down their fingers into the palm and then stretch their thumb and pinkie away from the hand.
- **Finger:** When an arm is extended, the distance across each finger (index, middle, or ring fingers) should be about one degree. The distance between the pointer stars of the Big Dipper is 5 degrees. Thus the two stars should appear

five finger-widths apart. Count how many fingers are needed by each student to cover the distance between the two pointer stars. If more than five fingers are needed to cover the distance, the fingers are less than one degree in width. If fewer than five fingers are needed, the fingers are greater than one degree in width. The moon and sun are a half degree in diameter. Therefore a finger should easily cover each. If a pinkie just covers the moon, then the pinkie is a half-degree across.

Note

To determine the actual angular spread of the fist, hand or finger, measure what combination of hand parts equal the latitude of Polaris.

- Finger: The distance between the end of your index finger and the nearest joint is about three degrees. The distance between the next two joints is about four degrees and the distance from the joint nearest your hand to your knuckle is about six degrees.
- Have each student complete the following chart using their hands:

Body Part	Average # of Degrees of Hand Parts	# of Degrees of Your Hand Parts
Upright fist	10 degrees	
Tip of index finger to end of pinkie	15 degrees	
End of thumb to end of pinkie	20 degrees	
Finger width	1 degree	
End of fingers to first joint	3 degrees	
First finger joint to second joint	4 degrees	
Knuckle to first joint	6 degrees	

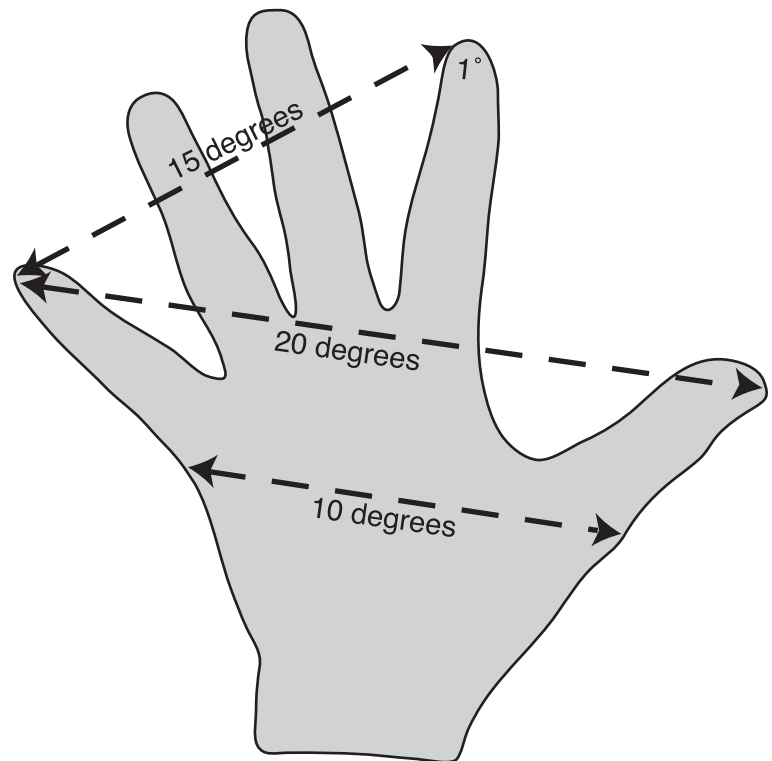
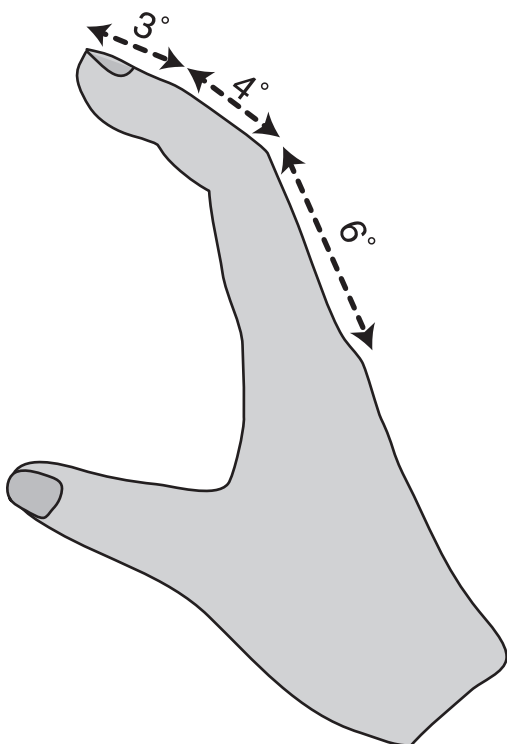

MATERIALS

- ruler
- measuring protractor
- a pencil
- books
- daylight

14. Finding the Sun's Altitude

Lewis and Clark measured the altitude of the sun at noon, also called the meridian altitude, to determine their latitude (the distance north or south of the Equator).

Objective

To determine the approximate altitude of the sun

Integrated Subjects

Science • Geometry

Process Skills

Measuring • Drawing

Procedure

- Place the protractor upright on a rigid, level table (located outside or next to a south-facing window) and secure it in place by attaching it to a large book (or book stack) with clay or tape.
- Turn the protractor (and books) so that the end of the protractor marked with zero degrees points towards the sun.
- Stand the pencil upright by inserting the pencil into clay. To be sure the pencil is upright, use a level or attach a weight to a string and loop the other end around the tip of the pencil. When the pencil is upright, the string will hug the pencil.
- Move the pencil (and its clay bottom) until its shadow exactly falls on the table at the center of the protractor.
- Carefully place one end of the ruler on the table at the center of the protractor and rest the other end of the ruler on the pencil tip.
- The altitude of the sun can be read where the bottom of the ruler crosses the protractor.

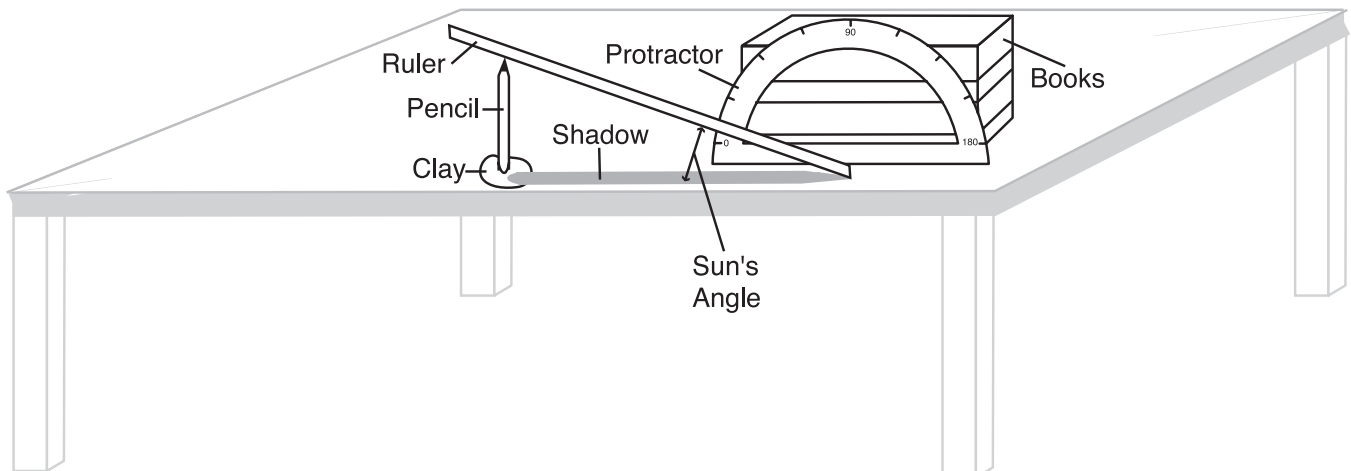

15. Finding Noon Using Shadow Lengths

Lewis and Clark used a technique termed “Equal Altitudes of the Sun” to determine their longitude. They observed the sun in the morning while having their morning meal then observed the sun in the afternoon while making a new camp. This activity is a variation on their procedures.

Rather than trying to measure the altitude of the sun at noon to find its altitude, we can find noon indirectly by finding the time when the morning and evening shadows of an object such as a pencil are the same length. By calculating the clock time that is exactly between the morning and evening equal shadow times, that time is the time of local noon (when the sun is at its highest position in the southern sky). Once local noon is known, one can find longitude by comparing the time of local noon to the time in Greenwich, England using a chronometer (an accurate clock).

Objective

To determine noon by using the sun’s equal morning and afternoon shadows.

Integrated Subjects

Science • Mathematics

Processing Skills

Observing • Measuring • Interpreting

Procedure

- Find a day when the sky is clear. Sometime during the morning hours, have the students put a pencil (or ring stand) upright into the ground. Record the time of the observation.
- Immediately use another pencil to mark the tip of the shadow of the first pencil on the ground. Then attach a loose pencil to a string that has a loop at the end and slip the loop of the string around the upright pencil. Use the second pencil to draw a circle around the upright pencil. The radius (r) of the circle should be equal to the length of the shadow.
- Throughout the day have the students check the length of the pencil’s shadow. As the sun climbs higher in the sky, the shadow will grow shorter, reaching its shortest length at local noon, when the sun is at its highest point in the sky. It can be difficult to try to determine when the shortest shadow has been reached because one doesn’t know that exact time until the shadow begins to lengthen by which time noon has passed. The shadow will lengthen in the afternoon as the sun moves lower in the sky. Watch the pencil’s shadow until it again reaches the circle that was drawn in the morning. Place another pencil upright into the ground to mark the spot. Have the students record the time.
- To find the time of local noon, find the time that is exactly half way in-between the equal-length morning and afternoon times (when the shadow reached the circle). The halfway time corresponds to the time of local noon. Noon is rarely at exactly 12:00. See activity 24. Finding Longitude Using a Lunar Eclipse.

Extension

To determine north and south, have the students use the three pencils that are inserted into the ground. To find south, draw a straight line connecting the morning and afternoon shadow points on the circle. Place a pencil at each of those points. Bisect the

MATERIALS

- ruler
- several pencils with sharp points
- string or thread

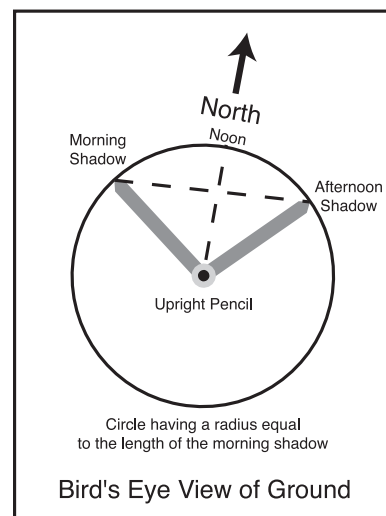

line using a pencil on a string and making an arc above and below the connecting line. Draw a line between the arcs. This line will point north and south. The direction away from the center of the circle between the shadows is the direction north.

16. Identifying the Ecliptic and the Zodiacal Constellations

Lewis and Clark observed the sun to determine their latitude and longitude. The Astronomical Almanac used by Lewis and Clark listed the position of the sun. But they could have determined the position themselves.

Because of the revolution of the Earth around the sun once each year, the sun appears to us on Earth to be moving eastward each day through the stars. Because the sun is so bright, one cannot see the stars nearby the sun, but can see the stars at sunset that are east of the sun. In the morning sky before sunrise, the stars west of the sun can be seen.

Objective

To deduce the constellations which lie along the ecliptic.

Integrated Subjects

Science • Art

Process Skills

Observation • Pattern Finding • Interpreting

Procedure

- Use a 2" x 2" Post-it™ note on the outside of the cylinder to block off the light from one of the zodiacal constellations. Explain that this is similar to the bright sun blocking our view of the stars around it.
- Move the cylinder so that the covered constellation is about to rise in the east. Which constellation is immediately to the west of the sunrise position?
- Turn up the side lights to simulate daylight and lower the stars to simulate the sun outshining the stars.
- Move the cylinder so that the blocked out stars have just set in the west. Which constellation is visible just after sunset?
- Using this information and the chart showing the zodiacal constellations, have the students deduce the constellation that was blocked out by the bright sun.
- Once the students are familiar with the zodiacal constellations, have them name the constellations and point out their position on the cylinder.
- How many constellations are there along the zodiac? Do they line up in a straight line or do they lie along a curved path? The curve is due to the tilt of the Earth on its axis so the direct rays of the sun sometimes fall above and sometimes below the Earth's equator.
- Have the students draw their own pictures of the zodiacal constellations.

MATERIALS

- STARLAB Portable Planetarium
- Lewis & Clark Cylinder
- Post-it™ notes
- The Zodiacal Constellations Chart

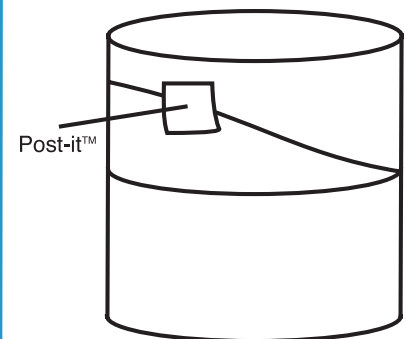

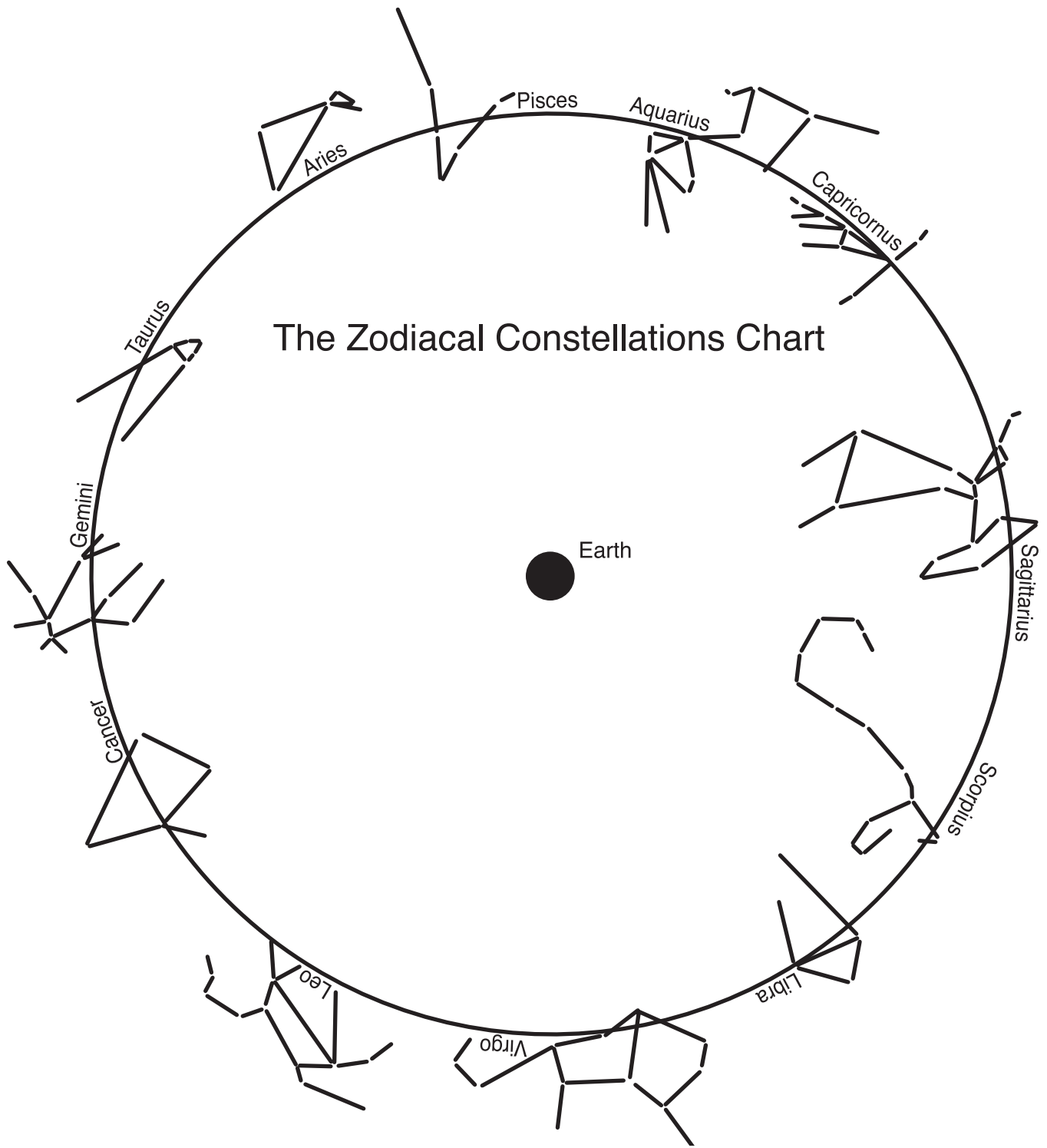

17. Day And Night

Lewis and Clark could have found their latitude by using several methods. One method was to measure the altitude of the sun at noon. Another method was to measure the altitude of the North Celestial Pole. Because the number of nighttime hours varies depending on the day of the year and latitude of the observer, one of these methods could not be used during one-half of the year.

Objective

To simulate day and night on Earth to show why Lewis and Clark could not use the North Celestial Pole to find latitude.

Integrated Subjects

Science • Geography

Process Skills

Observing • Interpreting

Procedure

- Stick a pencil into a Styrofoam ball. Hold the pencil upright so that the ball sits above the pencil.
- Place an "X" on the Styrofoam ball about half way up from the pencil.
- Hold the ball upright so that the sun lights half of the ball. Place the "X" towards the sun. The side facing the sun is having daylight.
- Turn the pencil counterclockwise so that the "X" moves away from the sunlight. The "X" is now moving toward the night. When the "X" is sitting on the light/dark line, this represents sunset.
- When the "X" is facing directly behind the sun, this represents midnight. Continue moving the ball until the "X" is on the light/dark line. This represents dawn. The Earth turns about its axis once each day. Day and night repeat each 24 hours.

The number of daylight and nighttime hours varies depending on the latitude and season.

- Place an "A" someplace on the top half of the ball, and a "B" on the bottom half of the ball. Hold the Styrofoam ball so that the top of the ball is tilted toward the sun, and rotate the ball counterclockwise. Note that the "A" located on the top half of the ball receives more sunlight than the "X" or the "B". When the Northern Hemisphere is facing the sun, position A has more daylight hours than nighttime hours in the summertime.
- Any measurements that required twelve hours of darkness could not be completed between March and September. Finding the North Celestial Pole requires two measurements of Polaris made twelve hours apart. Lewis and Clark could not accurately measure the location of the North Celestial Pole during the summer. Therefore they could not use the altitude of the North Celestial Pole to determine their latitude.

MATERIALS

- Styrofoam ball
- pencil
- felt marker
- sun

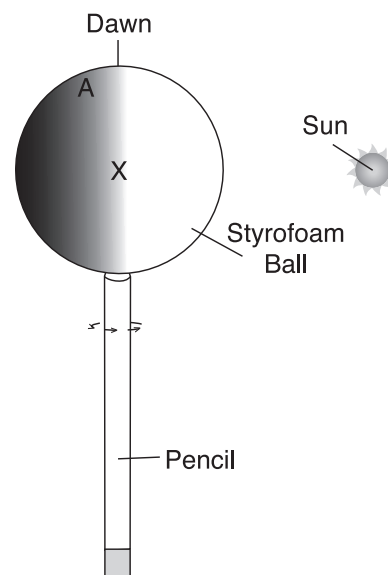

MATERIALS

- Earth globe
- 12 gumdrops sliced in half from top to bottom
- adhesive putty or Play-Doh®
- 24 flat toothpicks, pieces of tongue depressors, or popsicle sticks

18. Time and Longitude

Because the Earth turns once (360 degrees) in 24 hours, the Earth turns fifteen degrees each hour ($360 \text{ degrees} / 24 \text{ hours} = 15 \text{ degrees per hour}$). This information helped Lewis and Clark to determine their longitude.

Objective

How to use the difference in time to determine longitude.

Integrated Subjects

Science • Geography • Map Skills • Mathematics

Process Skills

Marking • Observing • Interpreting

Procedure

- Have the students look at a globe. They will find lines running between the North and South Poles. These lines are meridians of longitude. The zero degree meridian line, also called the Prime Meridian, is the starting point for finding longitude. It runs between the poles, but also runs through Greenwich, England. Write a "0" on a toothpick. Place the toothpick into a gumdrop and attach the gumdrop to the globe with a piece of putty.
- Turn the globe so that the Prime Meridian is directly in front of one student. Then gently move the Earth toward the right until the 15 degree west meridian line is in front of the student. The spinning Earth has just turned through one hour of time. Write a "1" on the toothpick, place the toothpick into another gumdrop, attach the gumdrop set in putty, to the 15 degree meridian. The "1" refers to the amount of time (one hour) that has passed since the Prime Meridian passed in front of the student.
- Continue moving the globe in 15 degree increments, repeat writing the number of hours that have elapsed on the toothpicks, and attach them to the globe with putty. The toothpick numbers tell you the number of hours each 15 degrees is behind Greenwich time. When you reach the twelfth hour, you are on the International Date Line that is exactly half way around the globe from the Prime Meridian. When you fly across the International Date Line from east to west (the direction we are moving), the day would change to the next day. When traveling from east to west, you lose a day. If it were Saturday in the United States, once you crossed the International Date Line going westward, the day would change to Sunday.
- At the International Date Line begin to count backwards. When the globe is turned the next 15 degrees, the number on the toothpick should read 11. Continue adding toothpicks with decreasing numbers at each 15 degree line. The numbers tell you the number of hours that specific meridian is ahead of the time at Greenwich.
- You should have 24 gumdrop halves, each with a number between 0 and 12 written on it. The last toothpick should also read zero. At the Prime Meridian, both toothpicks will read 0, meaning the time at Greenwich reads the same — except that it is a day later! We changed to the new day at the International Date Line.
- Time zones generally straddle the 7.5 degrees on each side of the 15 degree

meridians. To keep trading areas on the same time zone, some adjustments are made along the time zone boundaries. To convert to Greenwich Mean Time (GMT), add the correction numbers for your time zone to GMT. See chart below.

Time Zone	Standard Time	Daylight time
Eastern	5 hours	4 hours
Central	6 hours	5 hours
Mountain	7 hours	6 hours
Pacific	8 hours	7 hours

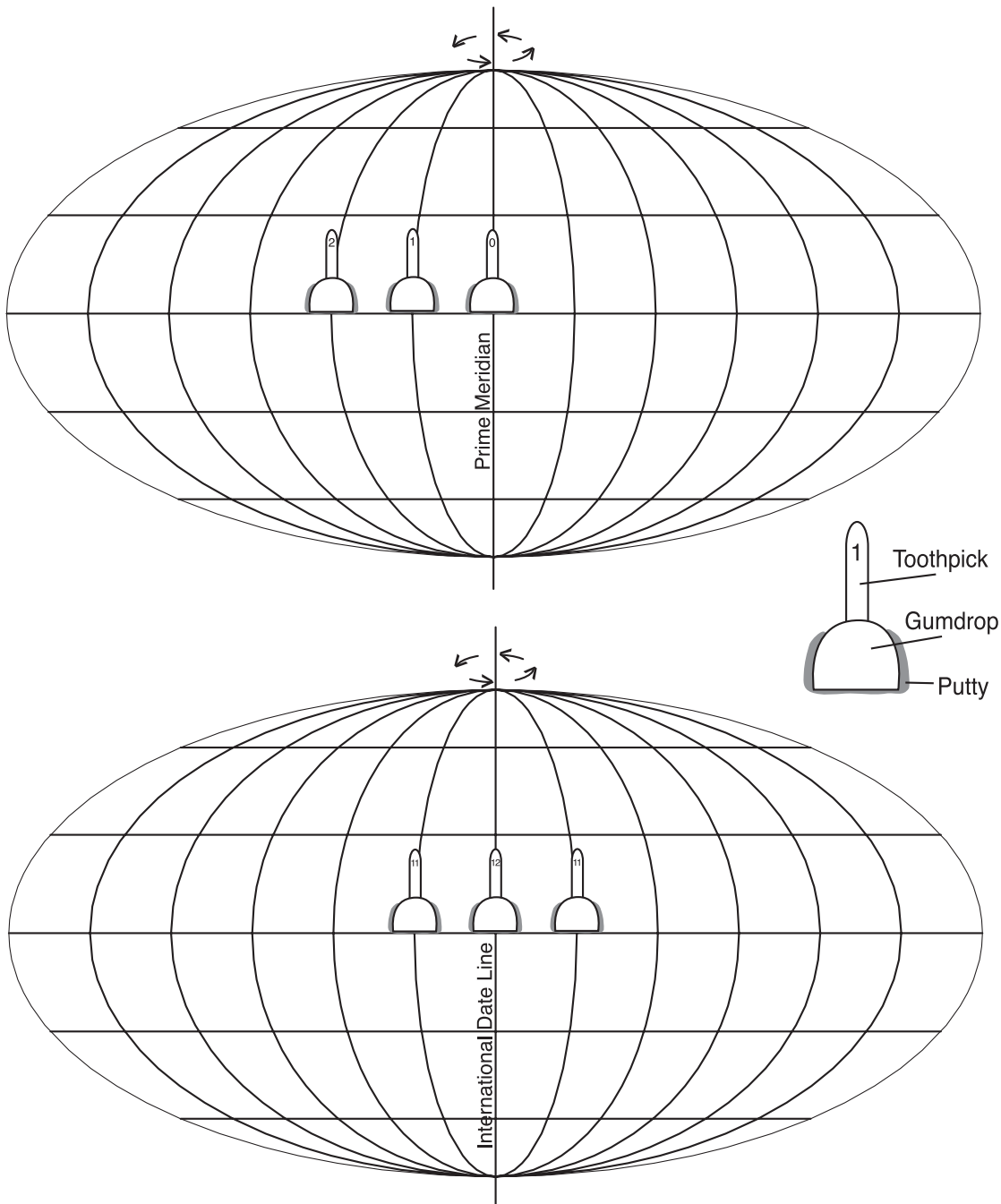

MATERIALS

- STARLAB Portable Planetarium
- Lewis & Clark Cylinder
- Star Chart of the Location of the Nine Stars

19. The Nine Navigation Stars of Lewis and Clark

Longitude can be found by measuring the angular distance between the moon and a planet or star. A table in the *Astronomical Almanac* carried by Lewis and Clark gave the positions of the moon in relation to nine bright stars that lay within or near the zodiacal constellations. This permitted them to determine their longitude.

To find longitude, the Captains looked for the moon at night and then found the closest of these nine stars to the moon. They then measured the angular distance between the moon and the star. Everyone on Earth saw the moon in about the same position relative to the star at the same time. The Captains knew their local time. They knew the time at Greenwich by using a table in the *Astronomical Almanac* which listed the time the moon and stars were specific distances from each other. From that they could determine the time difference, which gave them their longitude. The positions of the stars were given in the *Astronomical Almanac* in three hour increments (8 times a day), for every day of the year. However, the information in the *Astronomical Almanac* was meant for someone looking at the sky from the center of the Earth. Lewis and Clark were on the surface of the Earth which required another calculation involving spherical geometry. Additional calculations were necessary to be sure that the distance between the moon and star was measured parallel to the Celestial Equator, and to account for measuring from the edge of the moon, rather than its center.

Objective

To locate the nine stars used by Lewis and Clark and to find longitude.

Integrated Subjects

Science • Mathematics

Process Skills

Observing • Identifying • Pattern Recognition

Procedure

Using a star chart, find the location of the nine navigation stars of Lewis and Clark.

Star Name	Constellation (Latin)	Constellation (English)	Position in Constellation
Hamal	Aries	Ram	Head
Aldebaran	Taurus	Bull	Eye
Pollux	Gemini	Twins	Head
Regulus	Leo	Lion	Heart
Spica	Virgo	Maiden	Wheat in Hand
Antares	Scorpius	Scorpion	Heart
Altair	Aquila	Eagle	Heart
Markab	Pegasus	Flying Horse	Neck
Fomalhaut	Pisces Austrinus	Southern Fish	Mouth

Eight of the navigation stars are located within the zodiacal constellations. Pisces Austrinus, the Southern Fish, was located in a section of the sky where there are few bright zodiacal stars.

Navigation Stars Used at the Time of Lewis & Clark

- Hamal in Aries the Ram
- Antares in Scorpius the Scorpion
- Aldebaran in Taurus the Bull
- Altair in Aquila the Eagle
- Pollux in Gemini the Twins
- Markab in Pegasus the Flying Horse
- Regulus in Leo the Lion
- Fomalhaut in Pisces Austrinus
- Spica in Virgo the Maiden

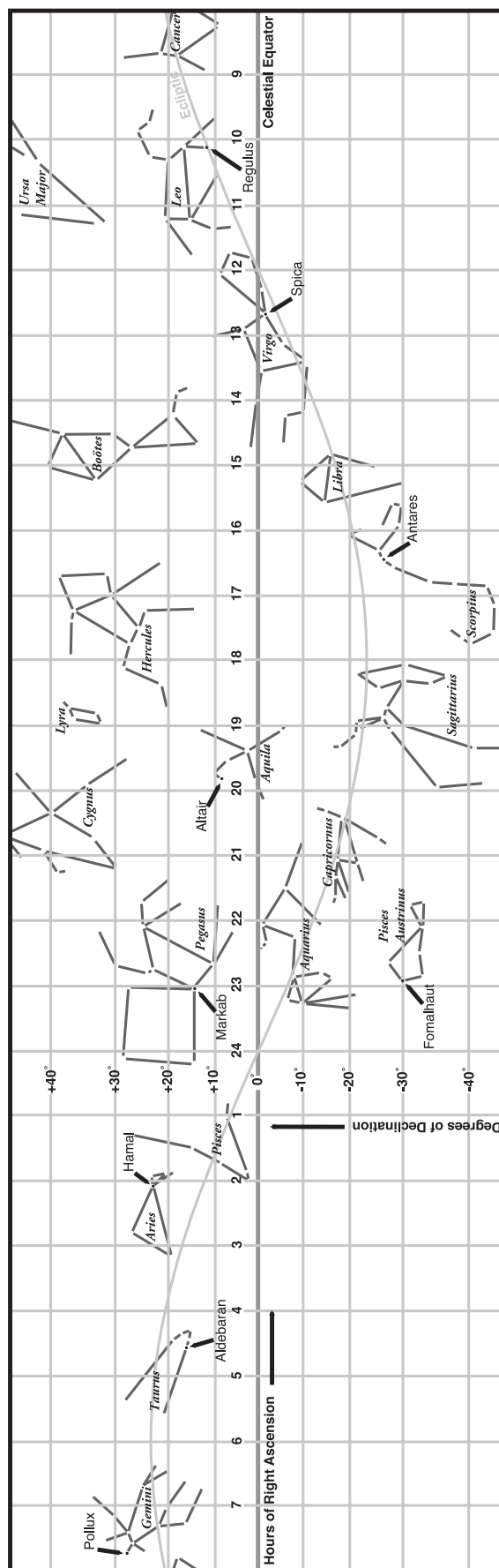

MATERIALS

- STARLAB Portable Planetarium
- Lewis & Clark Cylinder

20. The Relationship Between the Celestial Equator and the Ecliptic

Lewis and Clark measured the distance between the sun, moon, planets and stars as a method for determining where they were. To do this they needed to know about the relationship of two important imaginary lines in the sky.

One of the lines is called the **Celestial Equator**. This is formed by extending the Earth's equator into space. Imagine yourself sitting in the very center of the Earth and the Earth is transparent. The Earth's equator and the Celestial Equator would look to you like they were in the same place.

The other important imaginary line is called the **ecliptic**. If you were still sitting in the center of a transparent Earth and could plot the apparent location of the sun in the sky for a year, the path of the sun (caused by the Earth revolving around the sun), would form the ecliptic. Because the sun, moon, and planets are usually found near the ecliptic, the constellations that lie along the ecliptic are called the zodiacal constellations.

Objective

To observe the relationship between the Celestial Equator and the ecliptic.

Integrated Subjects

Science • Geography

Process Skills

Observing

Procedure

- Place the Lewis and Clark Cylinder so the latitude is zero — the cylinder should be upright. Find the Celestial Equator. Notice that the line runs parallel to the classroom floor.
- Find the ecliptic on the cylinder. Notice that the line is tilted to the floor, and that the constellations of the zodiac fall upon the line.
- As the sun moves along the ecliptic, it will intersect the Celestial Equator twice during a year. In which constellations are the intersections? The first day of spring occurs when the sun crosses the Celestial Equator when moving from the Southern Hemisphere into the Northern Hemisphere. The first day of autumn occurs when the sun moves from the Northern Hemisphere into the Southern Hemisphere in September. When the sun is at its farthest point north, the farthest from the Celestial Equator, this is the first day of summer. When the sun is farthest south from the Celestial Equator, this is the first day of winter.
- The number of degrees that the sun's direct rays are north or south of the equator for each day of the year can be found by using "The Apparent Declination of the Sun Throughout the Year Chart" (see activity 12), or by estimating the degrees that the ecliptic is from the Celestial Equator on the cylinder.

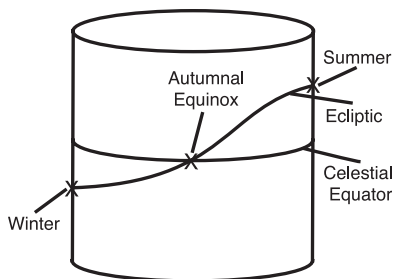

21. Phases Of The Moon

Lewis and Clark used the movement of the moon to determine their longitude. One of the charts they used is labeled "DISTANCES OF MOON's Center from SUN, and from STARS EAST of her". (See activity 23. How Much Does the Moon Move Each Night?).

As the moon revolves around the Earth, its position continually changes relative to the Earth and the sun. The amount of the sunlit portion of the moon that we see from Earth varies from day to day. Normally the lighted part of the moon is all that we are able to see. The unlighted part of the moon is dark and invisible. Moon phases are one of the hardest concepts for students to understand. By making the students part of a model, the phases are more understandable.

This activity gives directions for discovering the phases of the moon as seen in the Northern Hemisphere. The moon appears to move clockwise from the Southern Hemisphere and thus the directions should be reversed.

Objective

To discover why we see different phases of the moon.

Integrated Subjects

Science • Art • Physical Education

Process Skills

Calculating • Drawing • Modeling • Inferring

Procedure

- The paper plate will be used as the moon in our moon-phase model. Measure the diameter of the paper plate. The size of the Earth will depend on this measurement. Color one-half of the bottom of the paper plate black, using a crayon or magic marker.
- Take the class outside either early in the morning or late in the afternoon. The lower the sun in altitude, the longer the students' shadows.
- Have the students face the sun and decide how much of their body is lighted by the sun. (One-half.) Which side is lighted? The side facing the sun or the side away from the sun? (The side facing the sun.) The sun always lights one-half of any object facing it. Do the students cast a shadow? (Yes, the length depends on the time of day. The shadow is shortest at midday.)
- Draw an Earth with sidewalk chalk. The Earth is four times the diameter of the paper plate representing the moon. If you use a ten-inch paper plate, your Earth will have a diameter of 40 inches ($10'' \times 4'' = 40''$).
- With chalk, draw the orbit of the moon around the Earth. To use the same units for size of the Earth and moon and the distance of the moon from the Earth, the moon's orbit would have to be 120 times the size of the moon in your model. (The moon is located about 240,000 miles from Earth and the moon is 2,000 miles in diameter. Thus $140,000$ divided by $2,000 = 120$) A ten-inch moon would require an orbit drawn 1200 inches or 100 feet from the Earth.) A smaller orbit, not to scale, can be used.
- Have students walk on the moon's orbit you have drawn, moving counterclockwise around the Earth. As they walk have the students face the Earth. Have them

MATERIALS

- a sunny day!
- sidewalk chalk
- playground with surface to which chalk will adhere
- black crayon or magic marker
- paper plate

note that while facing the Earth, sometimes they are also facing the sun, sometimes they are looking away from the sun, at other times the sun is toward their right or their left. The students represent the moon moving around the Earth. The moon has one side that faces the Earth, just like the students always have their front side facing our planet. We on Earth, never see the backside of the moon. The reason is that the amount of time it takes the moon to orbit the Earth once (revolution), is equal to the time it takes to turn once on its axis (rotation).

- Place the paper plate on the ground on the moon's orbit so that the moon is located between the chalk Earth and the real sun. Have the white side face towards the sun and have the dark side pointing away from the sun. Have a student stand on the paper plate facing the Earth. Have his/her heels aligned along the terminator line, the point where the white and black meet.
- Move the class so that they are between the student and the sun and have them face the student. They should note that the sun lights the back of the student, and the white side of the paper plate is also toward the sun. The student standing on the paper plate represents the **New Moon**. Note that the student's shadow is pointing toward Earth. If the shadow of the moon falls upon the Earth, the result is an eclipse of the sun.
- Keeping the New Moon student and the paper plate in the same position, have several students move to the drawn Earth and have them face the moon. How much of the lighted portion of the moon do they see? (None.) A New Moon is not visible from the Earth unless it moves in front of the sun during a solar eclipse.
- Physically move the moon counterclockwise along the drawn moon orbit to a position 90 degrees from the New Moon position. Place the paper plate so that the white portion of the moon is facing the sun. Have a student stand on the moon so that he/she is facing the Earth. Have the class move to their first observation point between the moon's orbit and the position of the New Moon. How much of the moon is being lighted by the sun? (One-half.) How much of the student standing on the moon paper plate is being lighted by the sun? (One-half.) Have the students agree that the white portion of the paper plate is facing the sun. Move several students to the Earth and have them describe what they see. (The right sides of the student and the paper plate look lighted, their left sides are unlighted.) This is the position of the **First Quarter Moon**, when the right half of the moon as seen from Earth, is lighted. Is the amount of the light portion of the moon growing larger or smaller when compared to the New Moon position? (Getting larger.) A moon, which is growing larger each night, is called a **Waxing Moon**.
- Move the student and the paper plate representing the moon another 90 degrees so that the moon is now opposite from the position of the New Moon. Have a student stand on the moon as before, having the white half of the paper plate and the student facing the Earth. Have the class move to their first observation point between the Earth's orbit and the sun, and to observe that one-half of the moon (and the front of the student) is lighted by the sun. Send several students to the Earth position and have them look at the paper plate moon. How much of the moon is lighted? (One-half.) Which half is lighted? (The half facing the Earth.) This is a **Full Moon** phase. If the shadows of the students standing on the Earth position reach the moon, their shadows would create an eclipse of the moon.
- Finally move the paper plate moon and student another 90 degrees. Have the class repeat the steps from their previous observations. Which side of the student and moon are lighted now? (Left side.) Is the moon growing larger or smaller each night? (Smaller.) A moon which shows its left side lighted is called a **Third Quarter** or **Last Quarter** moon. A moon which is growing smaller from night to night is called a **Waning Moon**.

There are names for the phases of the moon which occur between those demon-

strated above. When less than one-half of the moon is lighted, the phase is referred to as a crescent. If more than one-half of the moon is lighted, the moon is in a **gibbous** phase.

The moon phases repeat every 29.5 days or about once a month. This chart provides a summary of moon phase information.

Moon Phase	Amount of the Lighted Half of the Moon Which is Facing the Earth	Date, if New Moon is on the First of the Month
New	None	1st
Waxing Crescent	Less than half of right side lighted	2 – 6th
First Quarter	Right half lighted	7th
Waxing Gibbous	More than half of the right side lighted	8 – 14th
Full Moon	All of the moon lighted	15th
Waning Gibbous	More than half of the left side lighted	16 – 21st
Last Quarter	One-half of the left side lighted	22
Waning Crescent	Less than one-half of the left side lighted	23 – 30th

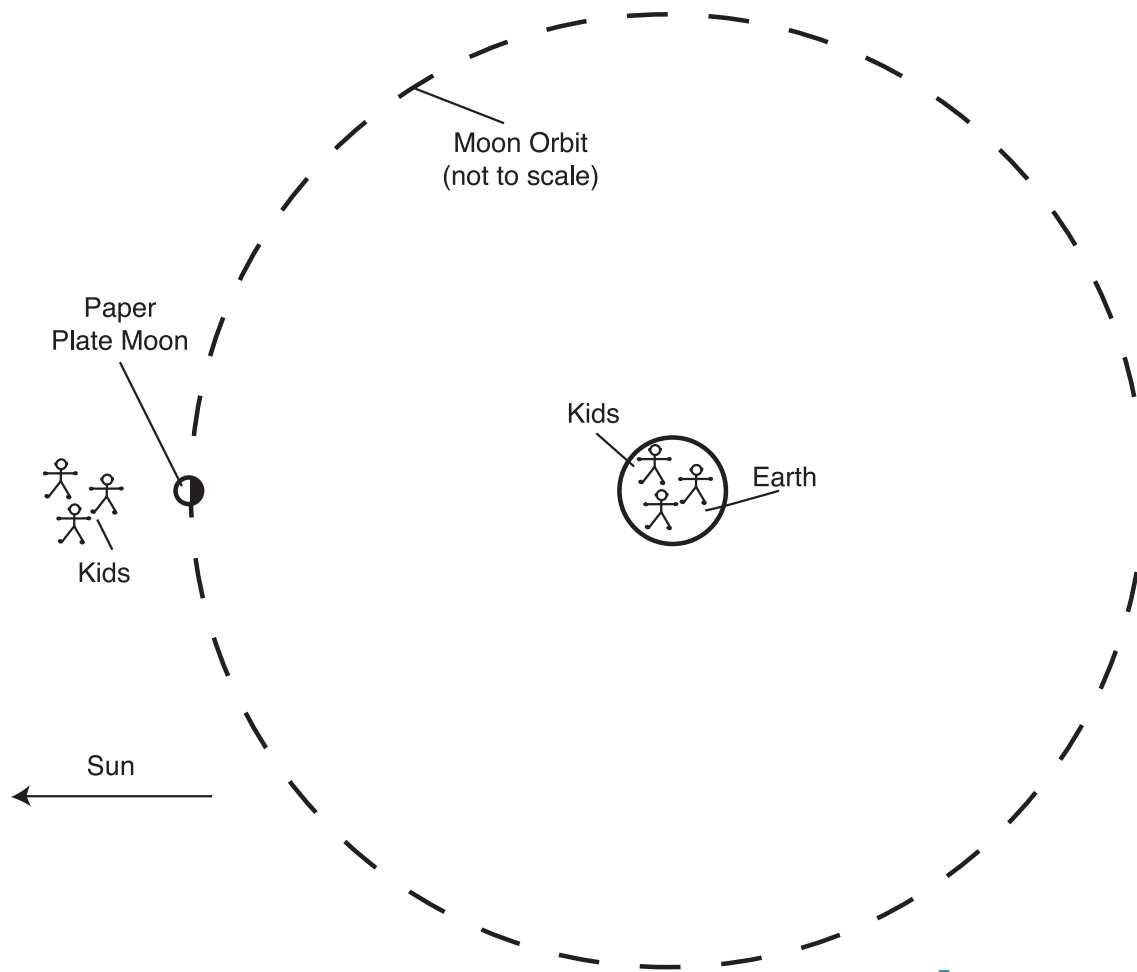

MATERIALS

- STARLAB Portable Planetarium
- Lewis & Clark Cylinder
- Starfield Cylinder

22. Moon Phases as Seen from the Earth

Lewis and Clark used the moon to establish their latitude and longitude. The moon changes shape and position continually as it revolves around the Earth every 27.3 days. Because the Earth is revolving around the sun at the same time, the phases of the moon as seen from the Earth, repeat every 29.5 days. The extra days are required for the moon to “catch up” with the Earth as it moves around the sun.

The following directions are given for observing the motion of the moon in the Northern Hemisphere. The moon appears to move clockwise in the Southern Hemisphere and thus the directions of the moon’s motions should be reversed.

Objective

To discover where and when to look for the phases of the moon.

Integrated Subjects

Science • Social Studies

Process Skills

Calculating • Modeling • Inferring

Procedure

- With the Lewis & Clark Cylinder on the STARLAB Projector, replace the small disk located at the Vernal (spring) Equinox with the New Moon disk.
- Have the students determine where the first Quarter Moon should be located (90 degrees counterclockwise from the New Moon at the Summer Solstice button). How much of the moon is always lighted by the sun? (Half.) How much of the lighted half is facing toward Earth? (Half of the lighted half — or a quarter, hence a “Quarter” Moon.) Which half should be lighted (Right.) Replace the Summer Solstice disk with the first Quarter Moon. Be sure that the lighted portion of the moon is pointed toward the sun.
- We can use the position of the sun to tell time. To simplify matters, let us assume that when the sun is rising in the east, it is 6 am. When the sun is located due south at its highest point in the sky for the day, it is noon. When the sun is setting in the west, it is 6 pm. Halfway between 6 pm and 6 am is midnight.
- Remove the New Moon disk. Because the New Moon and the sun are located toward the same direction in space, permit the light to shine through the hole. The unplugged hole represents the sun. Rotate the cylinder so that the first Quarter Moon is rising in the east. Where is the sun? (Due south.) The sun shows us that the time is noon. The first Quarter Moon rises in the east at noon. (We know that because that is where the sun is located in this model.)
- Move the STARLAB first Quarter Moon so that it due south. Where is the sun? (Setting in the west.) What time does the sun read? (6 pm.) What time is the first Quarter Moon due south? (6 pm.)
- Rotate the cylinder so that the moon is setting in the west. Find the sun (it should be on the floor in a midnight position). What time does the first Quarter Moon sun set? (Midnight.)
- Replace the first Quarter Moon with the New Moon disk and determine where the full moon should be located. (Opposite the sun at the Autumnal Equinox posi-

tion.) Remove the Autumnal Equinox disk and place the full moon disk over this button. Repeat the instructions given above.

The following chart summarizes the rise, noon, and set positions for each moon phase based on sunrise at 6 am and sunset at 6 pm. The Starfield Cylinder and the accompanying moon transparencies may be used to determine the rise and set times of the crescent and gibbous phases of the moon.

Moon Phase	Shape of Moon as Seen from Earth	Rise Time	Time Due South	Set Time
New Moon	Moon not visible	6 AM	Noon	6 pm
First Quarter	Right half of moon is lighted	Noon	6 pm	Midnight
Full Moon	All of moon is lighted	6 pm	Midnight	6 AM
Last Quarter	Left half of moon is lighted	Midnight	6 AM	Noon

Bird's Eye View of the Moon Phases

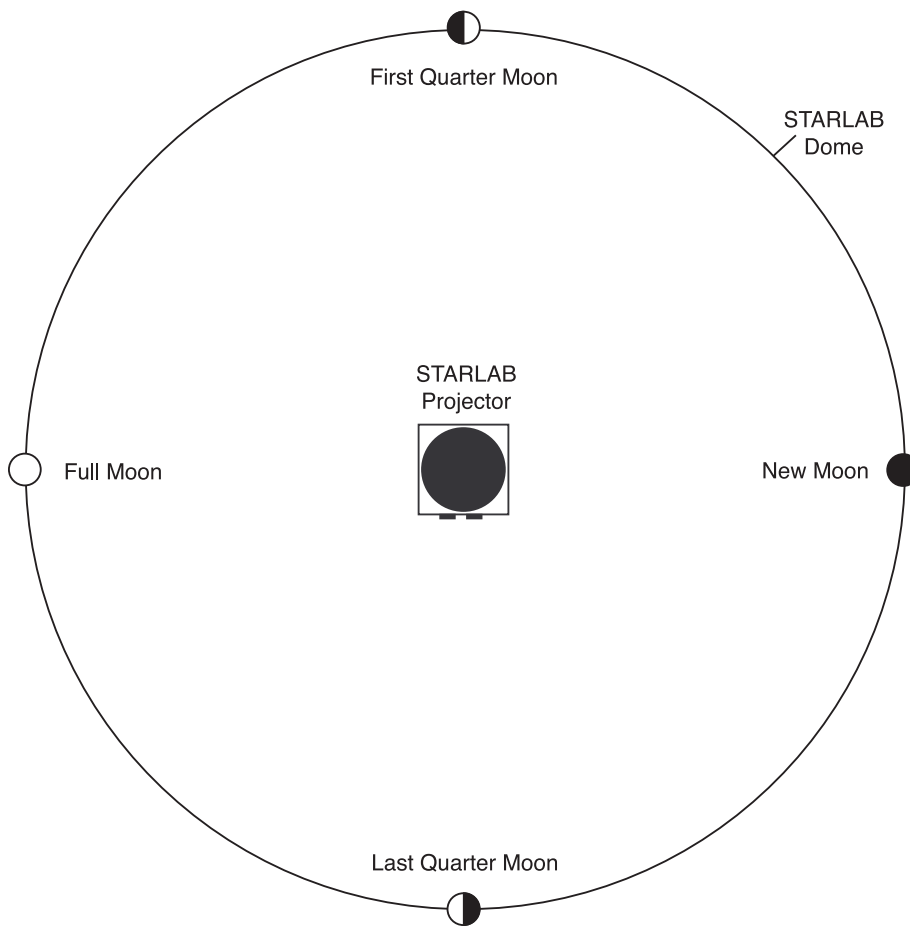

MATERIALS

- STARLAB Portable Planetarium
- Lewis and Clark Cylinder
- crescent moon cut out of cardboard

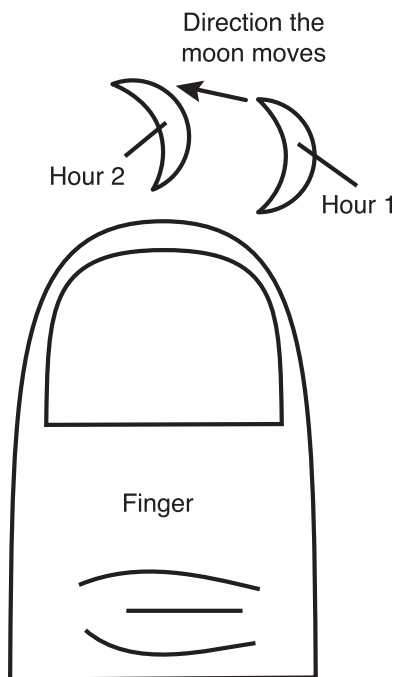

23. How Much Does the Moon Move Each Night?

The change of the position of the moon helped Lewis and Clark to determine their longitude. Information about the moon's change in position was found in the tables of the *Astronomical Almanac*, which listed the time, as predicted for Greenwich, England, when the moon was a certain distance from the sun or planet, or from one of the nine navigation stars. By noting their local time when they saw the moon in that position, they could find the difference between their time and the time in England. Longitude was found by knowing that for every hour of time difference equaled fifteen degrees in longitude difference.

Objective

Visualizing how much the moon seems to move each night due to its revolution around the Earth.

Integrated Subjects

Science • Mathematics

Process Skills

Observing • Measuring

Procedure

- Place the cardboard moon near the ecliptic found on the STARLAB dome. Demonstrate to the students how the moon appears to move counterclockwise (from the west towards the east in the STARLAB). Mention that to be completely accurate, the lighted portion of the moon should be increasing as the moon moves away from the sun, but that in this demonstration, we will not change the phase of the moon.
- Determine how much the moon seems to move each month. The moon completes one orbit around the Earth, as measured by the stars, every 27.3 days. The number of degrees the moon travels in one day is equal to 360 degrees divided by 27.3 which equals 13.1 degrees. The moon moves about a half degree per hour (13.1 degrees divided by 24 hours).
- To estimate this amount, hold your arm straight out. The moon moves about one-half of a finger width each hour, or an entire finger width in two hours.

See the next page for an actual moon position chart from the *1797 Astronomical Almanac* used by Lewis and Clark.

DISTANCES of MOON's Center from SUN, and from STARS EAST of her.

Stars Names	Days	Noon.	III.	VI.	IX.	Midnight.	XV.	XVIII.	XXI.
		D.M.S.	D.M.S.	D.M.S.	D.M.S.	D.M.S.	D.M.S.	D.M.S.	D.M.S.
α Arietis.	1	78.51.29	77.24.50	75.58. 9	74.31.24	73. 4.36	71.37.44	70.10.50	68.43.52
	2	67.16.51	65.49.46	64.22.39	62.55.28	61.28.15	60. 0. 59	58.33.40	57. 6.20
	3	55.38.57	54.11.32	52.44. 5	51.16.39	49.49.13	48.21.49	46.54.26	45.27. 7
	4	43.59.50							
Aldebaran.	1	73.12.40	71.39.19	70. 5.40	68.31.50	66.57.43	65.23.19	65.48.38	62.13.39
	2	60.38.23	59. 2.28	57.26.53	55.50.39	54.14. 5	52.37.11	50.59.57	49.22.22
	3	47.44.26	46. 6. 8	44.27.28	42.48.25	41. 9. 1	39.29.14	37.49. 5	36. 8.33
	4	34.27.39	32.46.21	31. 4.41	29.22.40	27.40.18	25.57.35	24.14.34	22.31.14
	5	20.47.35							
Pollux.	1	64.59.42	63.14.53	61.29.40	59.44. 3	57.58. 0	56.11.32	54.24.41	52.37.26
	2	50.49.48	49. 1.47	47.13.24	45.24.40	43.35.37	41.46.15	39.56.35	38. 6.37
	3	36.16.24							
Regulus.	1	72. 0.35	70. 9.10	68.17.26	66.25.24	64.33. 5	62.40.30	60.47.40	58.54.37
	2	57. 1.20	55. 7.51	53.14.13	51.20.25	49.26.28	47.32.25	45.38.18	43.44. 7
	3	41.49.54	39.55.40	38. 1.29	36. 7.21	34.13.19	32.19.22	30.25.35	28.32. 2
	4	26.38.44	24.45.42	22.53. 4	21. 0.49	19. 9. 2			
Spica.	1	- - -	- - -	- - -	- - -	73. 7.29	71.14.43	69.22.11	67.29.55
	2	65.37.56	63.46.15	61.54.53	60. 3.52	58.13.13	56.22.58	54.33. 7	52.43.41

8 January 1797 VIII

MATERIALS

- Original astronomical measurements of Lewis and Clark

24. Finding Longitude Using Equal Altitudes of the Sun

Lewis and Clark measured the elevation of the sun twice a day (morning and afternoon) and recorded the time of these measurements usually using an artificial horizon which doubled the actual elevation of the sun. The afternoon measurement had to be made when the sun was exactly at the same height above the horizon as when it was measured in the morning. The reason was to calculate the time of "local noon". Local noon was the sundial time at wherever Lewis and Clark were camping. Local noon was also the time when the sun was at its highest elevation in the sky for the day and when the sun was located due south. Local noon was important to the Corps of Discovery because that time could be used to determine the longitude, and with the use of charts, also the latitude of their camp.

We will look at Clark's actual calculations taken from his journal to understand how he calculated local noon (misspellings and all). Then you will have an opportunity to try your mathematical skills to find local noon using Clark's observations at the place where three forks met to form the Missouri River.

According to a modern computer program, noon on January 31, 1806, was at 12:29:53.

Objective

To use the measurements of William Clark to determine how he found the time of local noon.

Integrated Subjects

Science • Mathematics

Processing Skills

Calculating • Interpreting

Procedure

- Find the time of noon by finding the time between the morning and afternoon readings of equal altitudes of the sun. For example, William Clark measured equal altitudes of the sun at Fort Clatsop on January 31, 1806. Here are his measurements and his calculations for determining the time of local noon.

With Sextant — Equal Altitudes the Day 31st of January 1806 at Fort Clatsop

h	m	s	h	m	s	
8	52	28	1	9	3	Sun's Altitude:
"	55	24	"	12	13	40° 32' 00"
"	58	21	"	14	53	

Using the table on the next page, we can follow what he did: A little before 9 am (8 hours, 58 minutes, 21 seconds or 8:58:21) he measured the height of the sun as 40 degrees, 32 minutes, 0 seconds. Then he waited until the afternoon when the elevation of the sun was again 40 degrees, 32 minutes, 0 seconds. The time in the afternoon that this happened was just after 1 pm (1:09:03). Because the afternoon hours are mathematically "smaller in value" than the morning hours, he added 12

hours to the 1:09:03 which gave him 13:09:03. The corresponding "equal altitude" time in the morning of 8:58:21 was subtracted from the 13:09:03 which made it 4 hours, 10 minutes, and 42 seconds. This is the amount of time between the morning and afternoon readings.

He then took one half of the 4 hours, 10 hours, 42 seconds to find the midpoint in the time. The half time is 2 hours 5 minutes, 21 seconds. Then he added this 2 hours, 5 minutes, 21 seconds to the morning readings of 8 hours, 58 minutes, 21 seconds. This gave him the time of 11:03:42. This told him that the sun was on the meridian (due south) a little after 11 in the morning (11:03:42). This was the time of local noon at Fort Clatsop. He then compared the time of his local noon to Greenwich time. Because the chronometer was not accurate (he thought it was running too slowly), his longitude estimates for Fort Clatsop were off by about 50 miles.

Extension

Here are the measurements of the equal altitudes of the sun taken by Clark on July 28, 1805 at the confluence of the three forks of the Missouri. What time was local noon based on these measurements? Students might find it easier to change Clark's afternoon reading to military time.

	h	m	s		h	m	s	
A.M.	8	57	05.5		P.M.	4	5	50
	8	58	41			4	7	24
	9	00	14			4	8	29
								Altitude by sextant at the time of Observts. 77° 4' 45"

Three Forks, Montana, (45° 56 N, 111° 351 W) where this observation took place is too far north for the data given. The actual time for noon on July 28, 1805 at Three Forks was 11:32:20 AM, with the sun's maximum altitude of 63° 171 292. Data that works (though not from the Clark journal) would be:

Hours	Minutes	Seconds	Hours	Minutes	Seconds	
8	02	25	3	12	30	Altitude by sextant at the time of Observts. 40° 591 422
8	9	41	3	16	55	
8	12	00	3	20	15	

The altitude is the altitude at the final pair of readings, when they were the same.

*These readings and the following arithmetic sample, from **Clark's First Draft Field Book**, demonstrate how he determined local noon.*

	h	m	s
Chronometer too slow on Mean Equated Solar time —	1	10	26.1
	1	9	3
+ 12 hours —	12		
	13	9	3
- Corresponding observt P.M.	8	58	21
of which take half — 2	4	10	42
= to half interval of obst.	2	5	21
+ forenoon or A.M —	8	58	21
time that the O's center was on the Meridian as shown by the Chronometer — } }	11	3	42

Equal Altitudes of the Sun

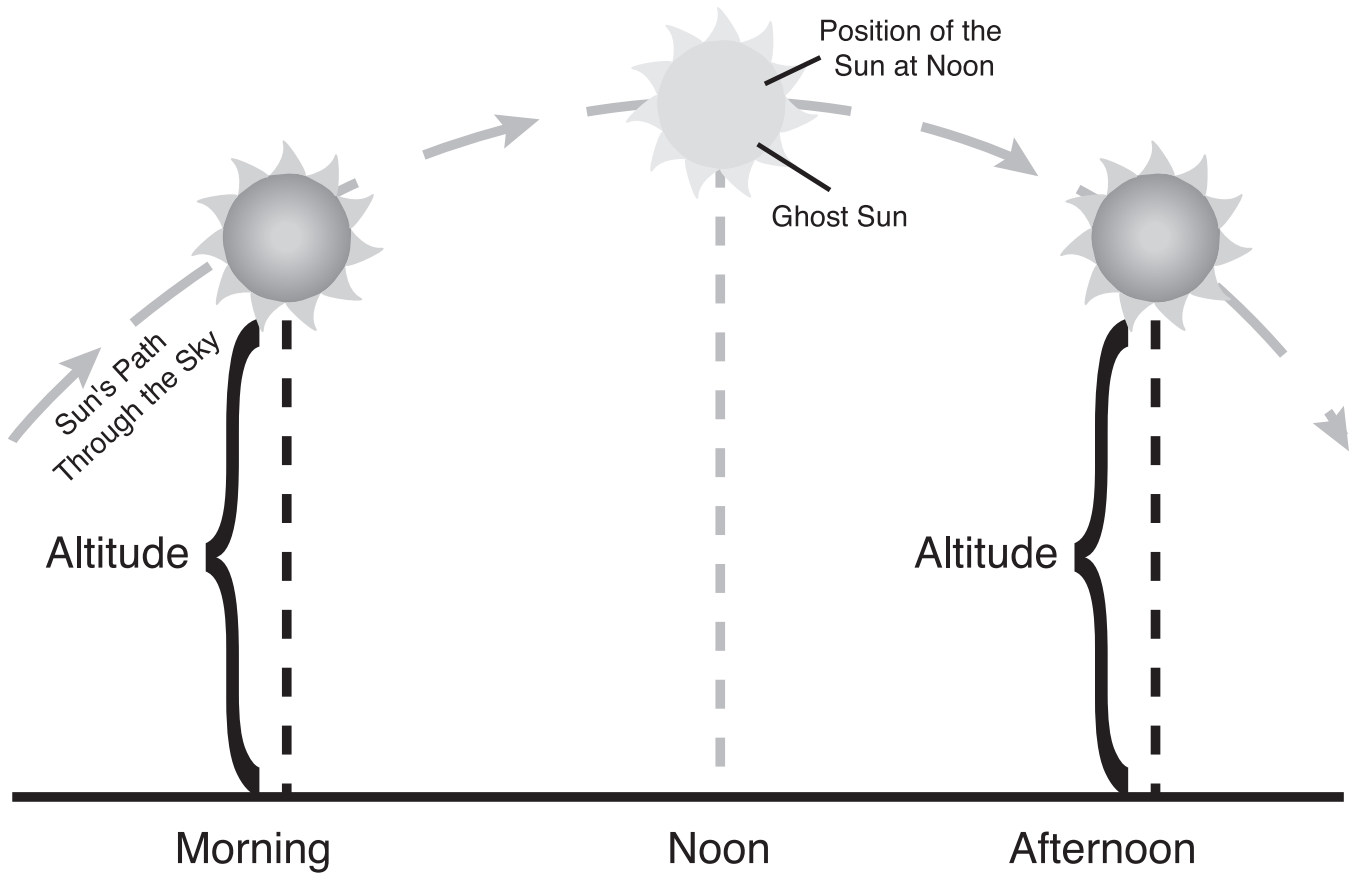

The morning altitude in degrees above the horizon must equal the afternoon altitude. The time exactly between equal altitudes is local noon.

25. Finding Longitude Using a Lunar Eclipse

Lewis and Clark used the difference between their local (sundial) time and the time in Greenwich, England, to determine their longitude. The difficulty was knowing the time at Greenwich. To find that time, an eclipse of the moon was used at Fort Mandan.

The moon moves eastward through the sky each day by about 12 degrees because of the moon's revolution around the Earth (see activity 23). If the moon moves into the shadow of the Earth, an eclipse of the moon occurs.

Lewis and Clark used the information about the moon's movement to determine the longitude of their position. There was a table in the *Astronomical Almanac* which listed the time in Greenwich, England, when the eclipse began and ended. Here is an example of how Lewis and Clark used an eclipse of the moon to find their longitude.

Objective

To determine longitude using an eclipse of the moon.

Integrated Subjects

Science • Mathematics

Process Skills

Observing

Procedure

- According to your watch, which is set on local or sundial time, the shadow of the Earth started moving across the surface of the moon at 7:04 pm. According to the tables in the *Astronomical Almanac*, the eclipse was predicted to begin in England at 11:26 pm. What is your longitude?

We know that the Earth turns 360 degrees in 24 hours, so the Earth turns 15 degrees per hour.

- To find longitude, find the time difference between Greenwich time and local time.
 $11:26 - 7:04 = 4 \text{ hours and } 22 \text{ minutes.}$
- The 4 hours equals 15 degrees x 4 (hours) or 60 degrees. The number of degrees equal to 22 minutes can be found with the following algebraic formula:
 $22/60 = x/15. \text{ Here } x \text{ is equal to } 5.5 \text{ degrees.}$
- So the 4 hours and 22 minutes is equal to a longitude of 65.5 degrees west of Greenwich.

MATERIALS

- STARLAB Portable Planetarium
- Lewis and Clark Cylinder
- cardboard circle with bottom left darkened

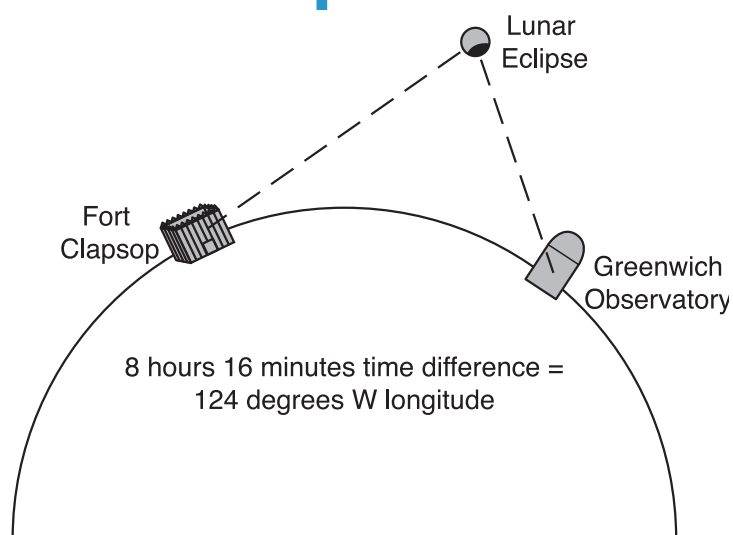

MATERIALS

- STARLAB Portable Planetarium
- Lewis & Clark Cylinder
- Post-it™ notes

26. Finding Longitude Using the Moon and a Star

The *Astronomical Almanac* carried by Lewis and Clark on their expedition gave the location of nine navigation stars plus the sun, relative to the moon. These positions were given for eight times each day. The Captains could interpolate the distances between the moon, sun and star positions for other times.

The procedure was that someone on the expedition (usually Clark) noted the local time, while Lewis measured the angular distance between the moon and a planet, or the moon and the sun. They then compared their local time, to the time in Greenwich when the objects were predicted to be at that distance, as given in the *Astronomical Almanac*. (See the chart accompanying activity 19. The Nine Navigation Stars of Lewis and Clark.) Because they knew their local time, as well as the time in Greenwich, the difference in time could be determined. And, using the time difference, they could calculate their longitude.

The Corps of Discovery determined their longitude at their first encounter with Missouri River Indians at Council Bluffs, Iowa. Next they measured the distance between the moon and Altair in Aquila the Eagle. At Great Falls, Montana, they measured distance between the moon and Antares in Scorpius, and also from Markab in Pegasus.

Measurements were made from the center of the moon, and from the center of the sun. The *Astronomical Almanac* gave the apparent diameters of each for each day. Thus after one determined the distance to the edge of the moon or sun, the radius of each object had to be figured into the calculations. Other corrections were needed for parallax, the bending of light by our atmosphere, which slightly changes the altitude of objects especially when the object is located near the horizon. The most time-consuming correction was to change the values of the Greenwich predictions, using spherical trigonometry, to reflect the latitude of the observer. The positions given in the *Astronomical Almanac* were for someone located in the center of the Earth.

Objective

To investigate how to determine the distance between the moon and a star.

Integrated Subjects

Science • Geography • Mathematics

Process Skills

Observing • Discovering • Measuring • Inferring

Procedure

1. Place a full moon in the position of the Summer Solstice, and draw an imaginary line from the center of the moon to the Celestial Equator, and note the position in Right Ascension where this line intersects the Celestial Equator. A pencil can mark the position on a Post-it™ note attached to the dome.
2. Determine which of the nine navigation stars is nearest to the full moon. Draw another imaginary line from the star to the Celestial Equator, and record the intersection with another Post-it™ note. Note whether the moon is east or west of the full moon.
3. Keeping in mind that 60 minutes equal an hour, subtract the times of the Right Ascension of the moon and star from each other to determine the distance in time of Right Ascension between the moon and star.

4. Knowing that one-hour of time is equal to fifteen degrees, determine the number of degrees that separate the two objects.
5. If we had a table that gave the position of the moon from the star on this night, we could use the table to find the time when the moon was predicted to be at this same angular distance in Greenwich. We could compare our local time to the time given in the table. See activity 24. Finding Longitude Using Equal Altitudes of the Sun for this mathematical procedure.
6. The difference between the two times of the same event, after the various corrections were made as noted above, would give us our longitude.

How to Measure Angular Distances

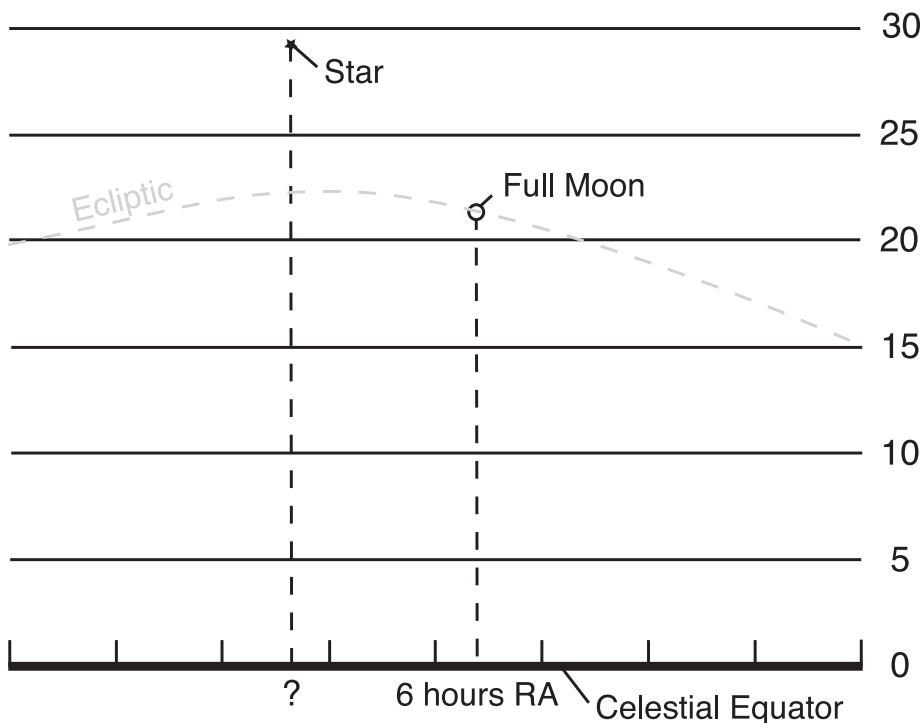

Read Right Ascensions (RA) along the Celestial Equator
(Units are measured in hours and minutes)

Recommended Resources

Lewis & Clark Expedition 1804–1806. Parchment paper (14" x 16") that shows a map of the route and gives a summary of the expedition. Suitable for a bulletin board. Historical Documents Co. 1983. \$1.00.

The Trail: Lewis and Clark 1804–1806. This bulletin board sized map shows the Lewis and Clark Trail, and the Oregon Trail, the Pony Express and Overland State routes, Fremont's Exploration, Butterfield's Denver State route, and the Santa Fe and Mormon Trails. Oregon Historical Society, 1230 SW Park Avenue, Portland, Oregon.

Copeland, Peter F. (1983) *The Lewis and Clark Expedition Coloring Book.* The 45 black and white plates of the paperback are designed to be colored, and illustrate the many activities of the expedition. Each of the 8.5 x 11 inch black and white plates is captioned. The front, back, and inside covers are colored plates. 48 pages. \$2.95. ISBN 0-486-24557-8.

Lewis and Clark Trail. A 16.5" x 24" folder produced jointly by the National Park Service and the Lewis and Clark Trail Heritage Foundation, Inc. One side of the folder contains a map of the Lewis and Clark expedition plus the visitor centers, parks, and areas that Lewis and Clark passed during their expedition. The reverse side of the folder gives a synopsis of the expedition, information about Lewis and Clark, and directions on how to follow the trail. Photographs taken along the route are numerous. This is a free publication.

"Lewis and Clark Sounds of Discovery" compact disk or audio tape. (1998) According to the audio tape "Sounds of Discovery is a musical journey recreating songs and sounds as they may have been heard by the members of the Corps of Discovery. The journey begins in Washington, D.C. in 1802 and follows the route of the expedition to the West Coast and back". The CD includes a 24 page, full color, booklet explaining the music and sounds. Produced by Makoche Music, Bismarck, ND. CD's are \$15.97, Tapes are \$10.98. ISBN 0-9650872-3-9.

People of the Willows CD. (1999) According to the CD cover "People of the Willows is a modern presentation of ancient Mandan and Hidatsa melodies which are full in richness of the culture as native flutes and vocals blend with piano, strings and percussions expressing the connections of music to all creation." A twelve-page booklet illustrates the story. Artists include Keith Bear, Gary Stroutsos, and Nellie Youpee. CD \$15.97. ASIN B0000/IVAD

A Map of the Lewis and Clark Track. William Clark produced this map after completing the expedition and filled in the unknown portion of the North American continent between North Dakota and the Pacific Ocean. Available from the Oregon Historical Society Press. Reprinted from the Archives of the Oregon Historical Society.

Photograph: Fort Clatsop: 7 December 1805 – 23 March 1806. Photography by Andrew E. Cier. This photograph of the rebuilt Fort Clatsop was taken during a reenactment of the 1805/06 winter. Available from the Lewis and Clark Heritage Centers.

Suggestions for Further Reading with Annotations

Readings for Teachers

Fifer, B & Soderberg, V. *Along the Trail with Lewis and Clark*. This publication provides detailed maps which show the route of Lewis and Clark, and the way to follow that route today. It includes the history of the expedition, and information about the sites, landmarks, and recreational activities along the trail. According to the back cover of this paperback book, Stephen E. Ambrose the author of *Undaunted Courage* says that this is the best guide book to the Lewis and Clark Trail. Published by Montana Magazine. \$17.95 ISBN 1-56037-117-X.

Coues, Elliott, Editor. *The History of the Lewis and Clark Expedition*. New York: Dover Publications. This three volume paperback series is a reprint of the four-volume 1893 Coues edition of the expedition. This editing of the writing of the journals of Lewis and Clark contains small reproductions of five of Clark's map, and a large copy of Clark's final map of the expedition. This series also contains an appendix which gives Clark's estimation of the distances to important geographical features such as the mouths of river, and Indian villages. It also contains all of the meteorological records taken between January 1, 1804 and August 31, 1806. 3 volumes, 1364 pages. Each volume is \$10.95 ISBN 0-486-21268-8.

Ambrose, Stephen E. *Lewis & Clark: Voyage of Discovery*. Published by the National Geographic Society. As with most National Geographic books, this publication mixes words and pictures nicely. Stephen Ambrose and his family retraced the Lewis and Clark trail. This book is a combination of his observations from his trip with writings from the Lewis and Clark journals. The photographs by Sam Abell bring this great exploration to life. \$35.00. 256 pages. ISBN 0-7922-7084-3.

Readings for Students

Hill, William E. & Hill, Jan. (2000) *West With Lewis and Clark, the Story of the Corps of Discovery*. According to the back cover of the soft cover activity book for primary school children, the workbook is "A blend of history and educational activities . . . 40 pages of fun-filled activities: coloring, dot to dot, map, recipes, music, mazes, figure-ground, word games, classification, art project and more!" Also included are directions for building a shoe box keelboat. Published by HillHouse, 91 Wood Road, Centereach, New York, 11720-1619. 40 pages. ISBN 0-9636071-4-6.

Morley, Jacqueline (1998). *Across America: The Story of Lewis and Clark*. This soft back book, designed for upper elementary students, traces the events of the Lewis and Clark expedition, from the dream of Thomas Jefferson to events following the conclusion of the Voyage of Discovery. Selected entries from the diaries of Lewis and Clark are richly illustrated □ with five, six or more entries and illustrations per page. Includes a glossary and an Index. Publisher is Franklin Watts Books, a Division of Grolier Publishing: New York. 32 pages. \$7.95. ISBN 0-531-15342-8.

Kiesling, Sanna Porte (1990) *The Lewis & Clark Expedition*. This soft cover story book, designed for students ages 8 years and older, is a summary of the journals of the Lewis and Clark Expedition. Most pages are illustrated. Published by Falcon Publishing, Inc.: Helena, Montana. 29 pages. \$7.95. ISBN 0-937959-60-X.



Constellation and Star Information

The Nine Navigation Stars of Lewis & Clark

1. Hamal — see Aries, page 61
2. Aldebaran — see Taurus, page 65
3. Pollux — see Gemini, page 64
4. Regulus — see Leo, page 64
5. Spica — see Virgo, page 63
6. Antares — see Scorpius, page 63
7. Altair — see Aquila, page 67
8. Markab — see Pegasus, page 68
9. Fomalhaut — see Pisces Austrinus, page 68

The Constellations of the Zodiac

Aries (The Ram)

Chief Stars

- α Hamal — orange giant, SC: K2, VM: 2.01, LY: 65.9
 β Sheratan — SC: A5, VM: 2.64, LY: 50
 γ Mesarthim — hydrogen double star, SC: A0, VM: 3.9, LY: 148 and 172

Of Special Note

Aries is a small constellation that lies between Pisces and Taurus with three faint stars that form the ram. Despite the fact that precession has caused the vernal point to shift into the constellation, Pisces, Aries remains one of the most famous of the zodiac constellations. From 2100 BC to 100 AD when stars tracked the passage of time, it was the stars of Aries that announced the spring equinox.

Pisces (The Fishes)

Chief Stars

- α Alrisha — double, SC: A2, VM: 4.33 and 5.23, LY: 130
 γ Gamma Piscium — yellow giant, SC: G8, VM: 3.69, LY: 125
 η Alpherq — SC: G8, VM: 3.62

Legend

Venus and her son, Cupid, changed themselves into fishes to escape Typhon, a fire-breathing dragon. Typhon could survive only in flames and fire but not in water. Venus and Cupid tied themselves together with a long cord so that they would not be separated.

Of Special Note

The vernal equinox occurs just south of Gamma Piscium. The sun passes through this point around March 21.

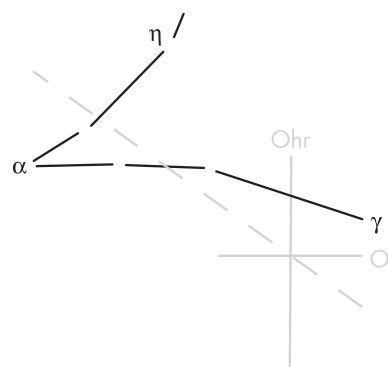
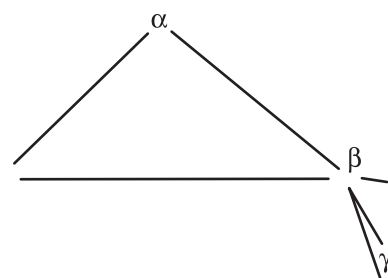

Abbreviation Key

SC = Spectral Class

VM = Visual Magnitude

LY = Light Years

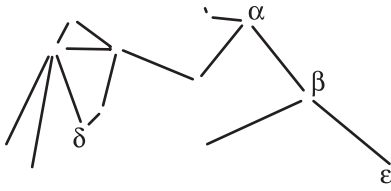

Abbreviation Key
 SC = Spectral Class
 VM = Visual Magnitude
 LY = Light Years

Aquarius (The Water Carrier)

Chief Stars

- α Sadalmelek — yellow supergiant, SC: G2, VM: 2.95, LY: 760
- β Sadalsud — supergiant, SC: G0, VM: 3.07, LY: 1100
- δ Skat — SC: A2, VM: 3.51, LY: 78
- ϵ Albali — SC: A1, VM: 3.83, LY: 172

Legend

Aquarius rises above the southern horizon in autumn. It is comprised of relatively faint stars but represents Aquarius, a giant, holding a huge upturned urn from which pours an unending stream of water.

Of Special Note

Within Aquarius are NGC 7089, a globular star cluster, Helix (NGC 7293) a planetary nebula and Saturn (NGC 7009) a nebula resembling the planet Saturn due to its position. The ecliptic passes right through Aquarius.

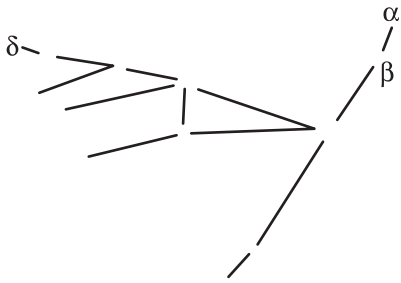

Capricornus (The Goat)

Chief Stars

- $\alpha 2$ Al Giedi — double, SC: G9, VM: 3.57, LY: 1100
- β Dabih — dwarf, SC: F8, VM: 3.08, LY: 250
- δ Deneb Algiedi — variable, SC: A5, VM: 2.87, LY: 50

Legend

The figure of a goat, the animal most famous for his climbing ability, was chosen to represent the constellation in which the sun was found at this time. The goat of the heavens is half goat and half fish, thus a creature not only able to climb, but also at home in the rains and floods of the winter season.

Of Special Note

Capricornus appears in the sky at the time of the winter solstice when the sun stops dropping and begins to climb higher and higher in the sky day by day. It is the tenth sign of the zodiac.

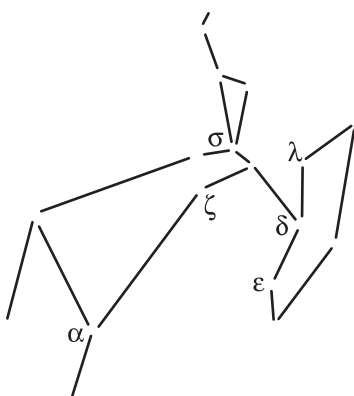

Sagittarius (The Archer)

Chief Stars

- α Rukbat (Alrami) — SC: B8, VM: 3.97, LY: 250
- δ Kaus Meridionalis — giant, SC: K2, VM: 2.70, LY: 136
- ϵ Kaus Australis — blue subgiant, SC: B9.5, VM: 1.79, LY: 147
- λ Kaus Borealis — giant, SC: K1, VM: 2.94, LY: 84
- σ Nunki — blue main sequence, SC: B2.5, VM: 2.05, LY: 224
- ζ Ascella — SC: A2, VM: 2.59

Legend

The Centaurs, half man and half horse, had the power and speed of a horse with the brains of a man. They were savage creatures, known for their evil ways except for Chiron who was known for his goodness and wisdom. Chiron was immortal, but due to a painful wound, he begged Jupiter to allow him to die rather than to live in agony. Jupiter granted his request. Before Chiron died, he designed all the constellations to aid the navigators. He designed Sagittarius to honor himself since he was known as a great archer.

Of Special Note

Within Sagittarius is the Trifid Nebula (NGC 6514 or M20), the Lagoon Nebula (NGC 6523 or M8) and the Swan (Omega) Nebula (NGC 6618 or M17).

Scorpius (The Scorpion)

Chief Stars

- α Antares — double star system, VM: 1.06, LY: 600
 - A — red supergiant, SC: M1.5
 - B — blue main sequence, SC: B4
- β Acrab (Graffias) — SC: B0 and B2, VM: 2.90, LY: 540
- δ Dschubba — blue subgiant, SC: B0, VM: 2.29, LY: 402
- λ Shaula — blue subgiant, SC: B2, VM: 1.62, LY: 700
- θ Sargas — yellowish bright giant, SC: F1, VM: 1.86, LY: 272

Legend

Juno, wife of Jupiter, arranged to have the scorpion kill Orion with its deadly sting to punish him for his boasting. When Diana, the goddess of the moon, learned of her lover's death, she begged Jupiter to place him as a constellation in the heavens. Juno demanded that Jupiter must also honor the scorpion in the same way, so he placed them far apart in the sky — Orion in the winter sky and the Scorpion in the summer sky.

Of Special Note

Within Scorpius lies three open clusters, NGC 6405 or M6 (the Butterfly Cluster), NGC 6475 or M7, and NGC 6322 and two globular clusters, NGC 6121 or M4 and NGC 6093 or M80.

Libra (The Scales)

Chief Stars

- $\alpha 2$ Zubenelgenubi — white subgiant, SC: A3, VM: 2.75, LY: 77
- β Zubenelchemali — helium, SC: B8, VM: 2.61, LY: 148
- γ Zubenelhakrabi — giant, SC: G8, VM: 3.91, LY: 109

Legend

Libra, the seventh zodiac constellation, is the only one that does not represent something living. In honor of Julius Caesar, the claw stars of the Scorpion were combined to form the figure of Caesar holding a pair of balance scales. The constellation was meant to be an eternal memorial in the heavens to the infinite wisdom and justice of Caesar. After Caesar's death, however, his figure was dropped out of the constellation picture and only the scales were retained.

Virgo (The Virgin)

Chief Stars

- α Spica — blue subgiant or giant and blue main sequence, SC: B1 and B2, VM: 0.98, LY: 262
- γ Porrima (Arich) — dwarf, SC: F0, VM: 2.75, LY: 35
- ε Vindemiatrix — yellow giant, SC: G9, VM: 2.83, LY: 93
- ζ Heze — SC: A3, VM: 3.37

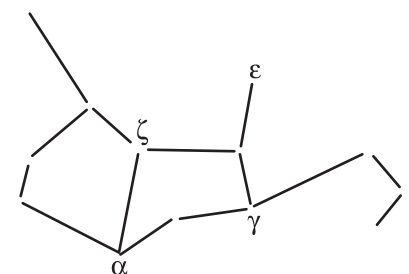
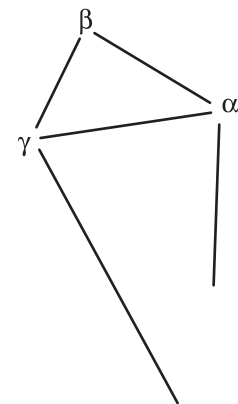
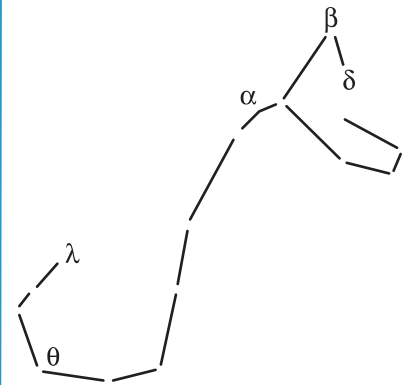

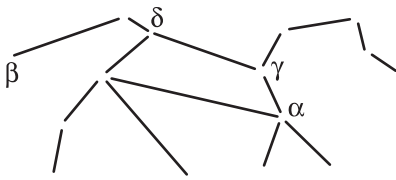

Of Special Note

Within Virgo are many galaxies that are viewable with a telescope. One in particular is M104 (Sombrero Galaxy) which does, indeed, look like a sombrero through a telescope.

Leo (The Lion)

Chief Stars

- α Regulus — multiple star system, VM: 1.36, LY: 77
 - A — blue main sequence, SC: B7
 - B — orange main sequence, SC: K1, VM: 8.13
 - C — dwarf
- β Denebola — double, white main sequence, SC: A3, VM: 2.14, LY: 36
- γ Algieba A — yellow-orange giant, SC: K0, VM: 2.01, LY: 126
- δ Zosma — SC: A4, VM: 2.56, LY: 68

Of Special Note

Leo is the fourth zodiac constellation lying directly on the ecliptic. Regulus was always a star of great importance to ancient astronomers who considered it to be the ruler over all other stars. Its duty was to keep them all in order and in their proper places in the sky. The majestic head and mane of Leo, the Lion are formed by the curving line of stars known as the Sickle. Within Leo are several bright barred spiral galaxies, NGC 3623, NGC 3627, NGC 3351 and NGC 3368.

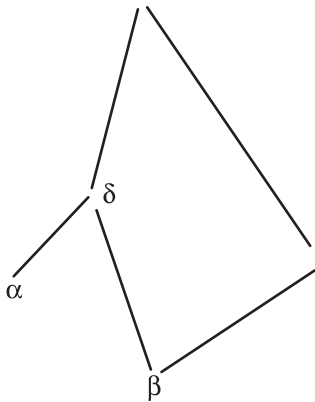

Cancer (The Crab)

Chief Stars

- α Acubens — double star, SC: F0, VM: 4.27, LY: 99
- β Altarf — SC: K4, VM: 3.52
- δ Asellus Australis — giant, SC: K0, VM: 3.94, LY: 220

Legend

Juno sent Cancer to annoy Hercules as he fought his desperate battle with the many-headed Hydra, the water snake. Hercules easily crushed the crab with his foot, but Juno who realized the creature had done its best in trying to serve her, rewarded it by placing it as a constellation in the sky (albeit very faint).

Of Special Note

Within Cancer are two open clusters, M44 (The Beehive or Manger), an easy naked-eye object to observe, and M67.

Gemini (The Twins)

Chief Stars

- α Castor — triple star system
 - A — white main sequence, SC: A1, VM: 2.0, LY: 45
 - B — main sequence, SC: A5, VM: 2.8
 - C — red main sequence dwarf, SC: M1
- β Pollux — orange giant, SC: K0, VM: 1.16, LY: 34
- γ Alhena — white subgiant, SC: A0, VM: 1.93, LY: 105
- ε Mebsuta — supergiant, SC: G8, VM: 3.18, LY: 1100
- μ Tejat — variable, SC: M3, VM: 2.88

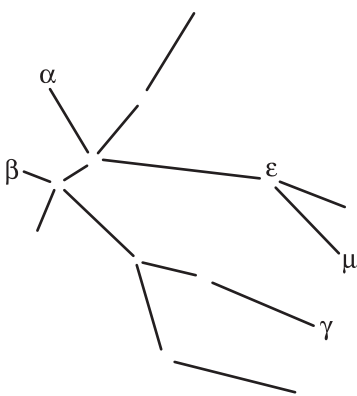

Legend

In Greek mythology, Castor (a mortal) and Pollux (immortal) were twin brothers so devoted to each other that they were inseparable. When Castor died in battle, Pollux begged Jupiter to take away his immortality so he too could die. Jupiter arranged for Pollux to spend half of each day with Castor in Hades, and Castor to spend the other half with Pollux on Mount Olympus among the Gods. Eventually Jupiter honored the twins by changing them into stars and placing them in the heavens as a memorial to brotherly love.

Of Special Note

Gemini, a zodiac constellation, has two very bright stars, Castor and Pollux. It is a good viewing point for planets as it is the culminating point of the ecliptic. The large constellation lies between Cancer and Taurus. Also within Gemini and viewable with binoculars is NGC 2168, an open star cluster.

Taurus (The Bull)

Chief Stars

α Aldebaran — orange giant, SC: K5, VM: 0.87, LY: 65

β Elnath — blue giant, SC: B7, VM: 1.65, LY: 131

Legend

Jupiter, disguised as a snow-white bull, came down from Mount Olympus one day to where Europa, a beautiful maiden, was playing in the meadow. The bull was so gentle that Europa climbed on its back. Then off sped Jupiter to the seashore, where he plunged into the waves and swam with his captive Europa across to the island of Crete. There, Jupiter revealed himself as the king of the gods and won Europa as his bride.

Of Special Note

Within Taurus, the second sign of the zodiac, lies the Pleiades (M45) or the Seven Sisters, an open star cluster with seven stars. Also lies a v-shaped asterism, the Hyades in the bull's mouth.

The Precession Constellations

Cepheus

Chief Stars:

α Alderamin — white main sequence, SC: A7, VM: 2.45, LY: 49

β Alfirk — variable double star, SC: B2, VM: 3.23 to 3.35, LY: 740

γ Alrai — subgiant, SC: A7, VM: 3.21, LY: 50

Legend

King Cepheus, King of Ethiopia and descended from Zeus, always played second fiddle to his wife, Queen Cassiopeia, who ruled the roost.

Of Special Note

Cepheus is intersected by the Milky Way and is full of many double stars, clusters and variable stars.

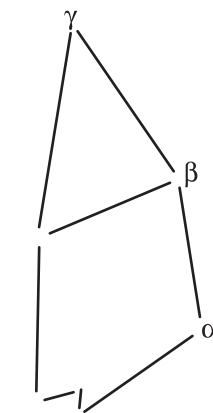
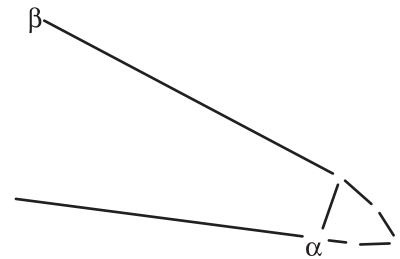

Abbreviation Key

SC = Spectral Class

VM = Visual Magnitude

LY = Light Years

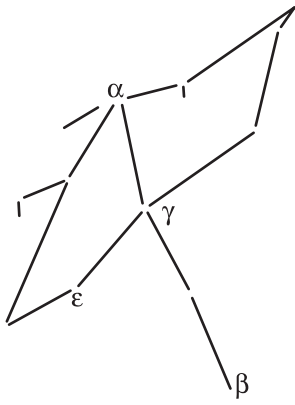

Cygnus (The Swan)

Chief Stars

- α Deneb — white supergiant, SC: A2, VM: 1.25, LY: 3200
- β Albireo — double star, VM: 3.05, LY: 386
 - A — yellow bright giant, SC: K3
 - Companion — blue
- γ Sadr — yellowish supergiant, SC: F8, VM: 2.23, LY: 1520
- ε Gienah — orange giant, SC: K0, VM: 2.48, LY: 72

Legend

Cygnus was the best friend of Phaeton, son of Apollo. When Phaeton was struck by lightning bolts and fell into the river Eridanus, Cygnus dove into the river over and over again in search of his body. Jupiter was so moved by the love and devotion that Cygnus showed for Phaeton that he turned Cygnus into a swan so he could dive more easily. Finally after Cygnus gave up in despair of ever finding the body of Phaeton, Jupiter placed him in the heavens as a swan.

Of Special Note

Alberio, a binary star, is noted for its two distinct colors, blue and yellow which can be seen using a telescope.

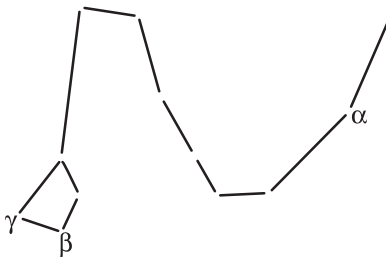

Draco (The Dragon)

Chief Stars

- α Thuban — white giant, SC: A0, VM: 3.67, LY: 309
- β Alwaid — double star, SC: G2, VM: 2.79, LY: 365
- γ Eltanin (Etamin) — orange giant, SC: K5, VM: 2.24, LY: 148

Legend

Draco is the dragon sent by Juno to guard the golden apples which she had given Jupiter as her wedding present to him.

Of Special Note

Thuban was very near the Celestial North Pole 4,500 years ago.

Lyra (The Lyre)

Chief Stars

- α Vega — white main sequence star, SC: A0, VM: 0.03, LY: 25
- β Sheliak — variable, VM: 3.4 to 4.3, LY: 1100
- γ Sulaphat — SC: B9, VM: 3.24

Legend

Mercury made the first lyre and presented it to Apollo, who in turn gave it to his son Orpheus. Orpheus learned to play such sweet music on it that birds came to listen, wild beasts were tamed and sea monsters charmed by the music's spell. After the death of Orpheus, Jupiter sent a vulture to bring back the lyre and he placed it in the heavens as a constellation.

Of Special Note

Within Lyra (between Sulaphat and Sheliak) is the planetary nebula NGC 6720 or M57.

Ursa Minor (The Little Bear)

Chief Stars

- α Polaris A — variable bright or supergiant, SC: F7, VM: 1.97, LY: 431
- β Kochab — orange giant, SC: K4, VM: 2.07, LY: 126
- γ Pherkad — SC: A3, VM: 3.05, LY: 180

Of Special Note

The Little Bear is better known as the Little Dipper. Polaris, the North Star, has been the guide star for those who sail their ships across the northern hemisphere and for those who travel across the land.

Other Important Constellations for Lewis & Clark

Aquila (The Eagle)

Chief Stars

- α Altair — white main sequence, SC: A7, VM: 0.76, LY: 16.77
- β Alshain — binary star system, VM: 3.71, LY: 44.7
 - A — yellow subgiant, SC: G8
 - B — red dwarf, SC: M3
- ζ Dheneb — SC: B9, VM: 2.99

Legend

The eagle was Jupiter's favorite bird and was given many difficult tasks to do.

Of Special Note

Altair is very close to Earth at only 16.7 light years. Also within Aquila is Eta Aquilae, a giant star from the spectral class G0. It is a variable star with a visual magnitude that varies from 4.1 to 5.3 in a 7.18 day period.

Cassiopeia

Chief Stars

- α Schedar — orange giant, SC: K0, VM: 2.24, LY: 229
- β Caph — yellowish giant to subgiant, SC: F2, VM: 2.28, LY: 54
- γ Cih — giant, SC: B0, VM: 2.2, LY: 650
- δ Ksora (Rucbar) — SC: A5, VM: 2.68, LY: 76
- ϵ Segin — SC: B3, VM: 3.38, LY: 470

Legend

Cassiopeia was placed in the sky to be punished for her vanity. She swings every half night around the North Star. She is upside down in the chair in which she is seated, hanging on for dear life in a position most humiliating for a queen so proud of her beauty.

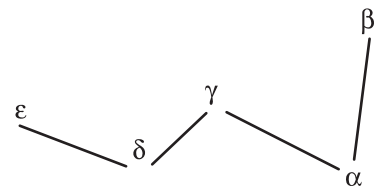
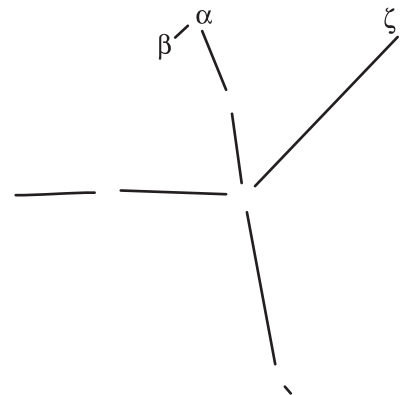
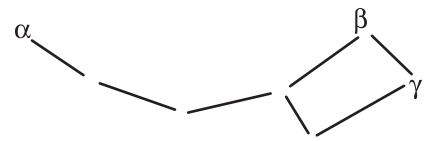

Abbreviation Key

SC = Spectral Class

VM = Visual Magnitude

LY = Light Years

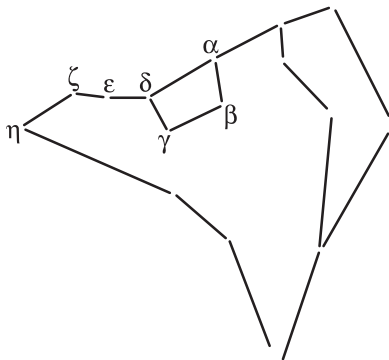
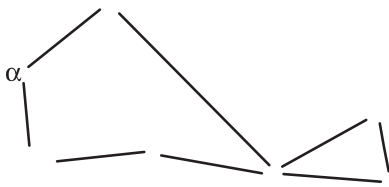
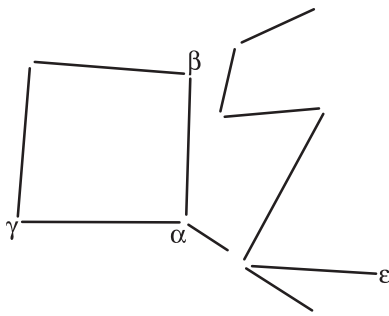

Abbreviation Key
 SC = Spectral Class
 VM = Visual Magnitude
 LY = Light Years

Pegasus (The Winged Horse)

Chief Stars

- α Markab — blue, SC: B9, VM: 2.49, LY: 140
- β Scheat — red giant, SC: M2, VM: 2.44, LY: 172
- γ Algenib — subgiant, SC: B2, VM: 2.83, LY: 333
- ϵ Enif — orange supergiant, SC: K2, VM: 2.38, LY: 670

Legend

Pegasus was the winged horse which carried Perseus through the sky as he returned the head of the Medusa. Neptune, who had loved Medusa when she was young and pretty, created Pegasus from white beach sand, rainbow-colored foam of breaking waves, and drops of blood from the severed head of Medusa.

Piscis Austrinus (The Southern Fish)

Chief Stars

- α Fomalhaut — white, SC: A3, VM: 1.17, LY: 25

Legend

Fomalhaut, meaning “mouth of the fish,” marks the mouth of the Southern Fish which is opened wide to catch the torrent of water pouring down from the upturned urn of Aquarius, the Water Carrier, located above Pisces Australis.

Of Special Note

Fomalhaut is the nearest young star to Earth, where planets appear to be forming.

Ursa Major (The Great Bear)

Chief Stars

- α Dubhe — orange giant, SC: K0, VM: 1.81, LY: 124
- β Merak — white main sequence, SC: A1, VM: 2.34, LY: 79
- γ Phecda — white main sequence, SC: A0, VM: 2.41 LY: 84
- δ Megrez — white main sequence, SC: A3, VM: 3.32, LY: 81
- ϵ Alioth — SC: A0, VM: 1.76, LY: 81
- η Alkaid (Benetnash) — blue main sequence, SC: B3, VM: 1.85, LY: 101
- ζ Mizar — white main sequence, SC: A1, VM: 2.23, LY: 78

Legend

Jupiter married a beautiful Earth maiden named Callisto. This enraged his goddess wife, Juno who sought revenge on Callisto by taking away her beauty — she turned Callisto into a mangy bear. One day while hunting, Callisto’s son, Arcas, was about to shoot a bear with an arrow when Jupiter intervened. The bear was, of course, his mother. Jupiter turned Arcas into a bear to join his mother. He grasped both bears by their short, stumpy tails and heaved them high up into the heavens where they landed near the North Pole. The bears were so heavy, the strain on their tails caused them to be stretched to the unusual lengths seen in their heavenly constellations.

Of Special Note

Dubhe and Merak form a line that intersects with Polaris A in Ursa Minor.